

RunCam Micro Swift

USER MANUAL



Connection

* Unplug the 5D-OSD menu cable after OSD setting.

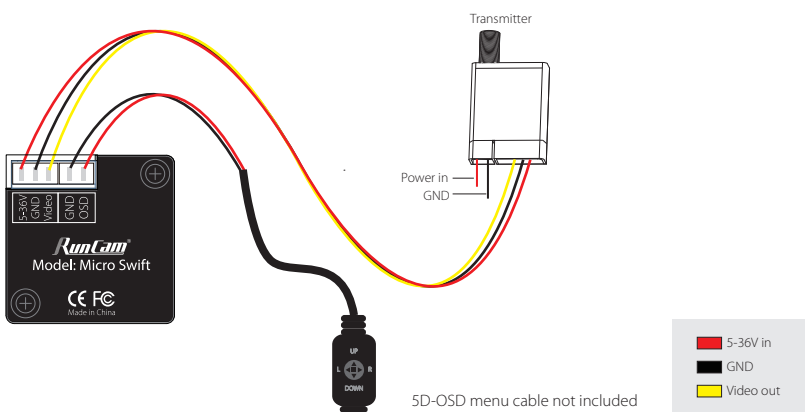

Dimensions & Installation

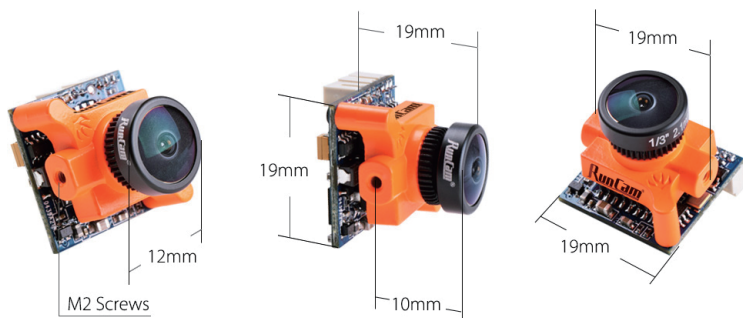

Parameters

Model	RunCam Micro Swift
Image Sensor	1/3" SONY Super HAD II CCD
Horizontal Resolution	600TVL
Lens	2.1mm Lens(M8)
Signal System	PAL/NTSC
S/N Ratio	>60dB (AGC OFF)
Electronic Shutter Speed	PAL: 1/50~100,000; NTSC: 1/60~100,000
Auto Gain Control (AGC)	Yes
Back Light Compensation (BLC)	Yes
Min. Illumination	0.01Lux@1.2F
WDR	D-WDR
DNR	2DNR
Day/Night	Color/Auto/B&W
Power	DC 5-36V
Net Weight	5.6g
Dimensions	19mm*19mm*19mm

Camera Menu

- MAIN MENU

SETUP		
CAM TITLE		OFF ↵
EXPOSURE		↵
BACKLIGHT		↵
WHITE BAL		ATW1
DAY & NIGHT		COLOR ↵
IMAGE ADJ		↵
DPC		↵
LANGUAGE		ENGLISH
RESET		↵
EXIT		

- CAM TITLE (ON/OFF)
- LANGUAGE (English/中文)
- WHITE BAL (ATW1 / ATW2 / AWC → SET / MANUAL: MANUAL, INDOOR, OUTDOOR)
- DPC (Cover the lens then press enter key)

- EXPOSURE

EXPOSURE		
SHUTTER		AUTO
BRIGHTNESS		050
AGC		ON
DWDR		ON ↵
RETURN		RET ↵

- SHUTTER (AUTO / 50-100000 / FLK)
- BRIGHTNESS (50 / 0-255)
- AGC (ON / LOW / MIDDLE / HIGH)
- DWDR (ON: 63 0-63 / OFF)

Camera Menu

- IMAGE ADJ

IMAGE ADJ		
LENS SHAD		OFF
2DNR		OFF
MIRROR		OFF
FONT COLOR		↵
CONTRAST		110
SHARPNESS		026
DISPLAY		USER ↵
NEG IMAGE		OFF
RETURN		

- LENS SHAD (OFF/ ON:22 0-255)
- CONTRAST (110 / 0-255)
- SHARPNESS (26 / 0-31)
- DISPLAY (CRT/LCD/USER)

USER ADJ.		
GAMMA		0.50
PED LEVEL		017
COLOR GAIN		176
RETURN		RET ↵

- GAMMA (0.5 / 0.05-1.0)
- PED LEVEL (17 / 0-63)
- COLOR GAIN (176 / 0-255)

Camera Menu

- BACKLIGHT (BLC / HLC / OFF)

BLC		
AREA SEL		AREA1
AREA STATE		ON
GAIN		042
HEIGHT		004
WIDTH		003
LEFT/RIGHT		006
TOP/BOTTOM		005
RETURN		RET ↵

- AREA SEL (AREA1/AREA2)
- GAIN (042 / 0-255)
- HEIGHT (4 / 0-10)
- WIDTH (3 / 0-9)
- LEFT/RIGHT (6 / 0-6)
- TOP/BOTTOM (10 / 0-10)

HLC		
LEVEL		200
MODE		ALL DAY
RETURN		RET ↵

- LEVEL (200 / 0-255)
- MODE (ALL DAY / NIGHT ONLY)

Camera Menu

- DAY & NIGHT (AUTO / COLOR / B&W / EXT)

D & N AUTO		
D → N LEVEL		080
D → N DELAY	3	SEC
N → D LEVEL		032
N → D DELAY	1	SEC
RETURN		RET ↵

- DAY → NIGHT LEVEL (80 / 0-176)
- DAY → NIGHT DELAY (3 / 1-30)
- NIGHT → DAY LEVEL (032 / 0-255)
- NIGHT → DAY DELAY (1 / 1-30)

D & N B & W		
BURST		OFF
IR SMART		OFF
IR LEVEL		HIGH
RETURN		RET ↵

- BURST (OFF/ON)
- IR SMART (OFF/ON)
- IR LEVEL (HIGH/LOW)