

BDS/GNSS Full Constellation Positioning And Navigation Module

ATGM332D-5N

User Manual



Hangzhou ZhongKe Microelectronics CO.,Ltd.

10F Innovation Tower,3850# Jiangnan Avenue Binjiang, Hangzhou,China

Tel : 0571-28918107

Fax : 0571-28918122

Website : <http://www.icofchina.com>



Version update history

Version	Date	Update content
1.0	2015/7/01	First draft of the 5 N series
1.1	2015/12/1	Add product purchase instructions; Add order model instructions; Add the same series of single GPS module, single BDS module function; Add Flash, online upgrade protocol and other characteristics; Revised application circuit diagram of the active antenna; Add application circuit diagram of the passive antenna; Modify the phone call for technical support; Other text improvement;
1.2	2016/7/15	Text Improvement



1 Function Description

1.1 Summary

The ATGM332D-5N series of module, package size for the 12.0mmX16.0mm is a general term of high performance BDS/GNSS whole constellation positioning and navigation module series. The series of module products are based on the fourth generation low power consumption GNSS SOC single chip of Zhongke micro - AT6558, support a variety of satellite navigation systems, including the Chinese BDS (Beidou satellite navigation system), American GPS, Russian GLONASS, EU Galileo, Japanese QZSS and Satellite enhanced system SBAS (WAAS, EGNOS, GAGAN, MSAS). AT6558 is a real sixes in one multi-mode satellite navigation and positioning chip, including 32 tracking channels, can simultaneously receive GNSS signals of six satellite navigation systems and implement joint positioning, navigation, and timing.

ATGM332D-5N series of modules have high sensitivity, low power, low cost and other advantages, suitable for vehicle navigation, handheld positioning, wearable devices and you can directly replace the LEA series modules of Ublox.

1.2 Product Purchase

Type	Multimode Function	Power	Interface	Characteristic
------	-----------------------	-------	-----------	----------------



	GPS BDS GLONASS	2.7V~3.6V 1.65V~3.6V	UART1 UART2	Flash TCXO Antenna Detection Antenna Over Current Protection Pre-SAW External LNA
ATGM332D-5N-1X	•	•	• •	• • • • • •
ATGM332D -5N-2X	•	•	• •	• • • • • •
ATGM332D -5N-3X	• •	•	• •	• • • • • •
ATGM332D -5N-5X	• •	•	• •	• • • • • •
ATGM332D -5N-7X	• • •	•	• •	• • • • • •

1.3 Performance Indicators

- Good positioning and navigation function, support BDS/GPS/GLONASS satellite navigation single system positioning and any combination of multiple system joint positioning, also support QZSS and SBAS system.
- Support A-GNSS
- Cold start - Recapture sensitivity: -148dBm
- Tracking sensitivity: -162dBm
- Positioning Precision: 2.5m (CEP50)
- The Time To First Fix: 32s
- Low Power: Continuous operation <25mA (@3.3V)
- Built-in Antenna Detection and Short-circuit Protection Function

Note1: Performance indicators above apply to ATGM332D-5N-1X、ATGM332D-5N-3X、ATGM332D-5N-5X、ATGM332D-5N-7X module.

Note2: ATGM332D-5N-2X module performance indicators, please confirm to the sales representative.



1.4 Module Function Diagram

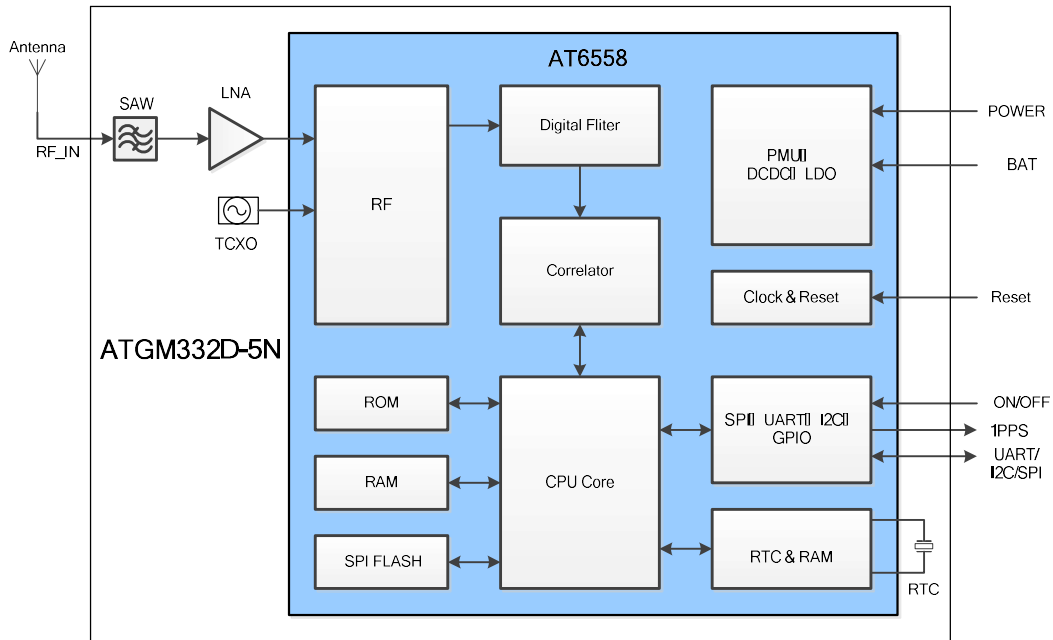

1.5 Product Application

- Vehicle positioning and navigation
- Mobile phone、Tablet PC、Handheld device
- Embedded positioning equipment
- Wearable Devices

1.6 Assisted GNSS (Assisted GNSS、AGNSS)

ATGM332D-5N series of module all support GNSS (AGNSS) function. AGNSS can provide the receiver with the necessary auxiliary information, such as the message, the rough position and time. Whether it is in the strong signal or weak signal environment, these informations can significantly shorten the positioning time for the first. Specific use see the note " AGNSS solution of ZhongKe micro".



1.7 PPS

ATGM332D-5N series of module supports precise second pulse output and the rising edge of the pulse is aligned with the UTC time.

1.8 Output Protocol

ATGM332D-5N series of module through the UART as the main output channel output in accordance with the NMEA0183 protocol format. Specific information, please refer to the "CASIC multi mode satellite navigation receiver protocol specification".

1.9 FLASH

ATGM332D-5N series of module is equipped with Flash, you can update the positioning function and algorithm through online upgrade. This configuration function, can allow the customer to autonomous configure the update rate in order to obtain suitable low power; can allow customers to update the latest optimization progress of the global multi-mode positioning ;can allow customers to add new control features, such as location records, rules of geographical fences, custom output formats.

1.10 Online Upgrade Function

ATGM332D-5N series of module supports online upgrade protocol of the ZhongKe micro. Users can communicate with the module in the host computer according to the upgrade protocol. The new software program, which will be provided by the ZhongKe micro, is upgraded to the module to obtain new software features. Users can also use a remote command, and remote control device to start the upgrade process above to realize the remote online upgrade. Online upgrade protocol, please



refer to the "ATGM module online upgrade protocol ".

1.11 Antenna

ATGM332D-5N series of module supports active antenna and passive antenna.

1.12 Host Computer Tool

Zhongke micro provide the"GNSSToolKit" Lite version of the software package (Windows version, Android version), used to locate output parsing and work mode configuration. Zhongke micro provide the "UBF serial port upgrade tool" software package (Windows version), used to online upgrade tools based on PC. Online upgrade program based on equipment required to develop customers themselves .



2 Technical Description

2.1 Appearance Size (Unit : mm)

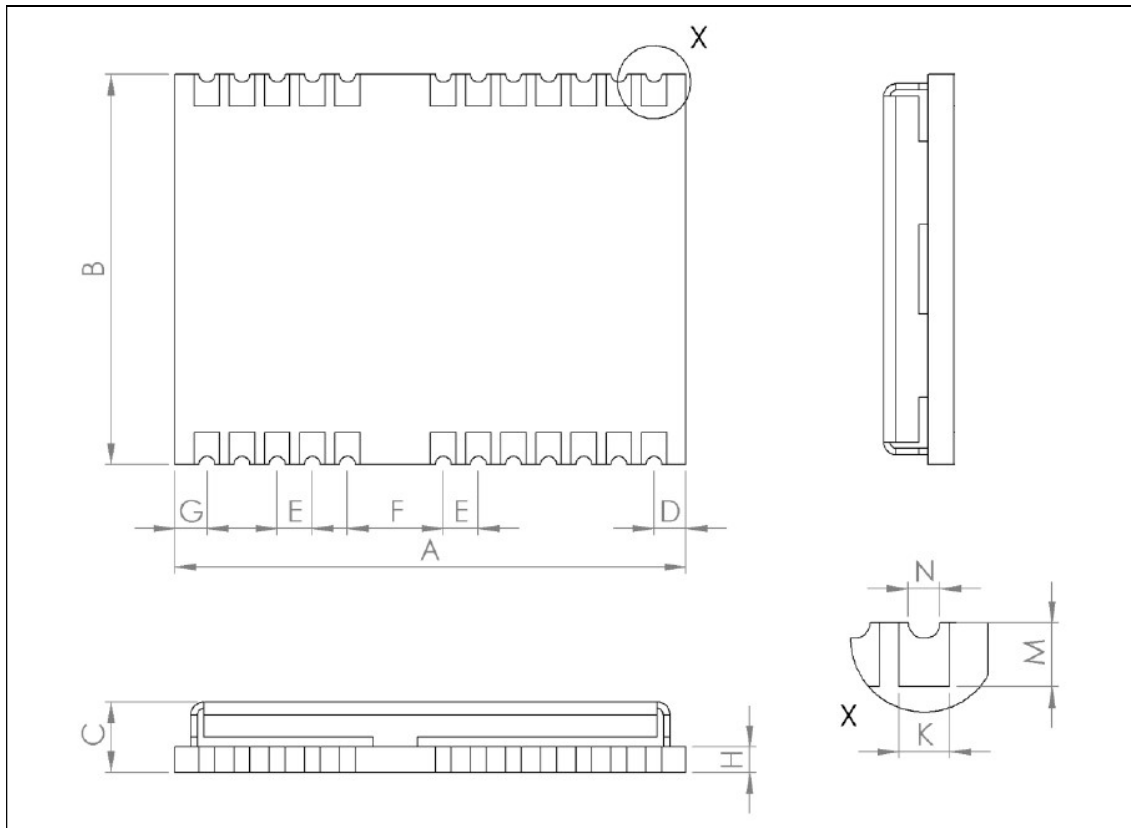

Symbol	Min.(mm)	Typ.(mm)	Max.(mm)
A	15.9	16.0	16.6
B	12.1	12.2	12.3
C	2.2	2.4	2.6
D	0.9	1.0	1.3
E	1.0	1.1	1.2
F	2.9	3.0	3.1
G	0.9	1.0	1.3
H		0.8	
K	0.7	0.8	0.9
M	0.8	0.9	1.0
N	0.4	0.5	0.6



2.2 PCB layout (Unit : mm)

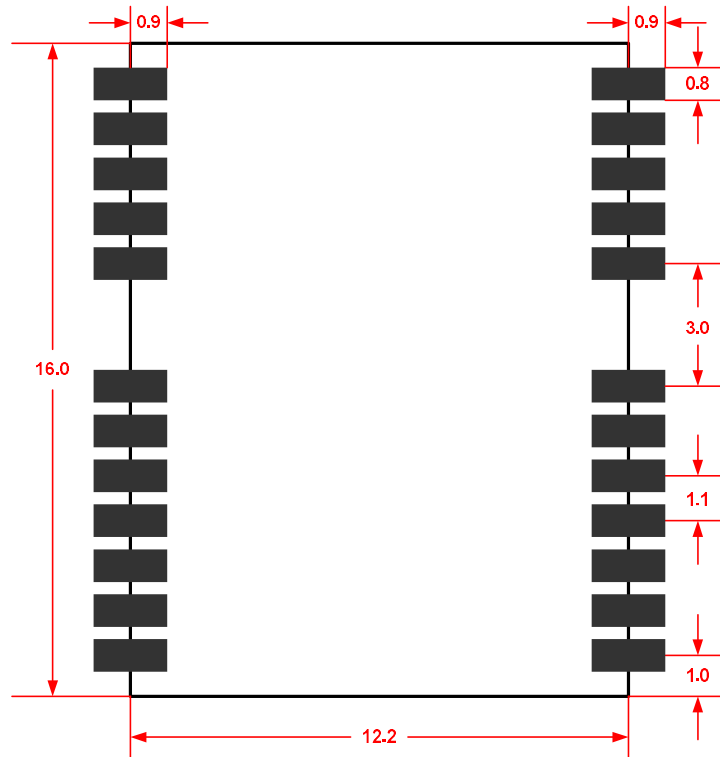

2.3 PIN Arrangement Diagram

13	GND	GND	12
14	NC	RF_IN	11
15	NC	GND	10
16	TXD2	VCC_RF	9
17	RXD2	nRESET	8
ATGM332D			
Top View			
18	SDA	NC	7
19	SCL	NC	6
20	TXD1	NC	5
21	RXD1	Reserved	4
22	VBAT	1PPS	3
23	VCC	Reserved	2
24	GND	NC	1



2.4 Pin Definition

Pin NO.	Name	I/O	Description	Electrical Characteristics
1	NC			
2	Reserved			Left floating
3	1PPS	O	Second pulse output	
4	Reserved			Left floating
5	NC			
6	NC			
7	NC			
8	nRESET	I	Module reset input, low level effectively	Left floating when not in use
9	VCC_RF	O	output power supply	+ 3.3V ,Power supply for antenna
10	GND	I	Ground	
11	RF_IN	I	Antenna signal input	
12	GND	I	Ground	
13	GND	I	Ground	
14	NC			
15	NC			
16	TXD2	O	Auxiliary serial data output, can be used for code upgrade	
17	RXD2	I	Auxiliary serial data input, can be used for code upgrade	
18	SDA	I/O	I ² C Data Interface	Left floating
19	SCL	O	I ² C Clock Interface	Left floating
20	TXD1	O	Navigation data output	NMEA0183 protocol
21	RXD1	I	Interactive command input	Configuration command



				input
22	VBAT	I	RTC and SRAM backup power supply	1.5~3.6V power supply to ensure that the module hot start
23	VCC	I	Module power input	DC 3.3V±10% ,100mA
24	GND	I	Ground	

2.5 Electrical Parameters

Limit Parameters

Parameters	Symbol	Minimum value	Maximum value	Unit
Module power supply voltage (VCC)	Vcc	-0.3	3.6	V
Backup battery voltage (VBAT)	Vbat	-0.3	3.6	V
Digital input pin voltage	Vin	-0.3	Vcc+0.2	V
Maximum acceptable level of ESD	VESD(HBM)		2000	V

Operating Conditions

Parameters	Symbol	Minimum value	Typical value	Maximum value	Unit
Power supply voltage	Vcc	2.7	3.3	3.6	V
Vcc Peak Current (not including antenna)	Ipeak			100	mA
Backup power supply	Vbat	1.5	3.0	3.6	V
Backup power supply	Ibat		10		uA



(Vbat) current					
Input Pin	Vil			0.2*Vcc	V
	Vih	0.7*Vcc			V
Output Pin	Vol Io=-12mA			0.4	V
	Voh Io=12mA	Vcc-0.5			V
Active antenna output voltage	VCC_RF		3.3		V
Antenna Short-circuit Current,Power from VCC_RF (=3.3V)	Iant short		50		mA
Antenna Open-circuit Current,Power from VCC_RF (=3.3V)	Iant open		3		mA
Antenna gain	Gant	15		30	dB

2.6 Technical Specifications

Indicators	Technical Parameters
Signal receiving	BDS/GPS/GLONASS/GALILEO/QZSS/SBAS
RF channel number	Three-channel RF, support the whole constellation BDS, GPS and GLONASS receiving at the same time
Cold Start TTFF	≤32s
Hot start TTFF	≤1s
Recapture TTFF	≤1s
Cold start capture sensitivity	-148dBm



Hot start capture sensitivity	-156dBm
Recapture sensitivity	-160dBm
Tracking sensitivity	-162dBm
Positioning Precision	<2m (1 σ)
Speed Measurement Precision	<0.1m/s (1 σ)
Timing Precision	<30ns (1 σ)
Positioning Update Rate	1Hz (default) , Maximum 10Hz
Serial Port Characteristic	Baud rate range : 4800 bps ~115200 bps, default 9600bps, 8 data bits , No check, 1 stop bit
Protocol	NMEA0183
Maximum Height	18000m
Maximum Speed	515m/s
Maximum Acceleration	4g
Backup battery	1.5V ~ 3.6V
Supply Voltage	2.7V ~ 3.6V
GPS&BD Typical power consumption	<25mA @3.3V
Working Temperature	-40 to +85 $^{\circ}$ C
Storage Temperature	-45 to +125 $^{\circ}$ C
Size	16.0mm \times 12.2mm \times 2.4mm
Weight	1.6g

2.7 Module Application Circuit

2.7.1 Active antenna solutions (Internal of module provides antenna power supply,



antenna detection and short circuit protection.)

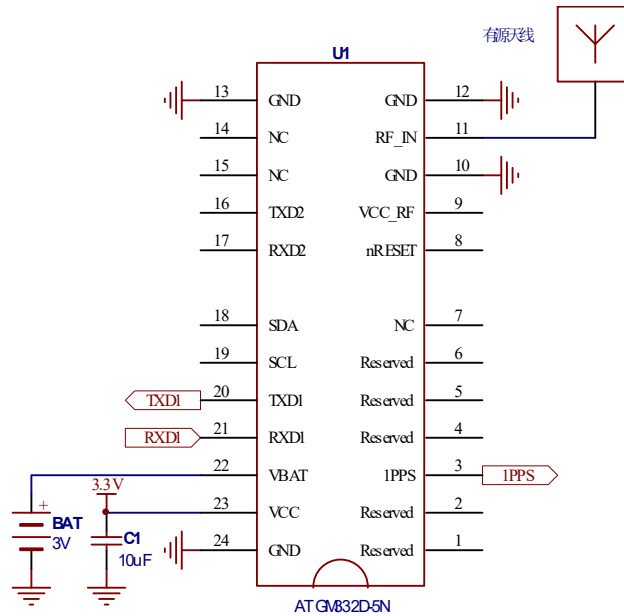

2.7.2 Passive antenna solutions (In RF_IN input of the module increased one level of LNA)

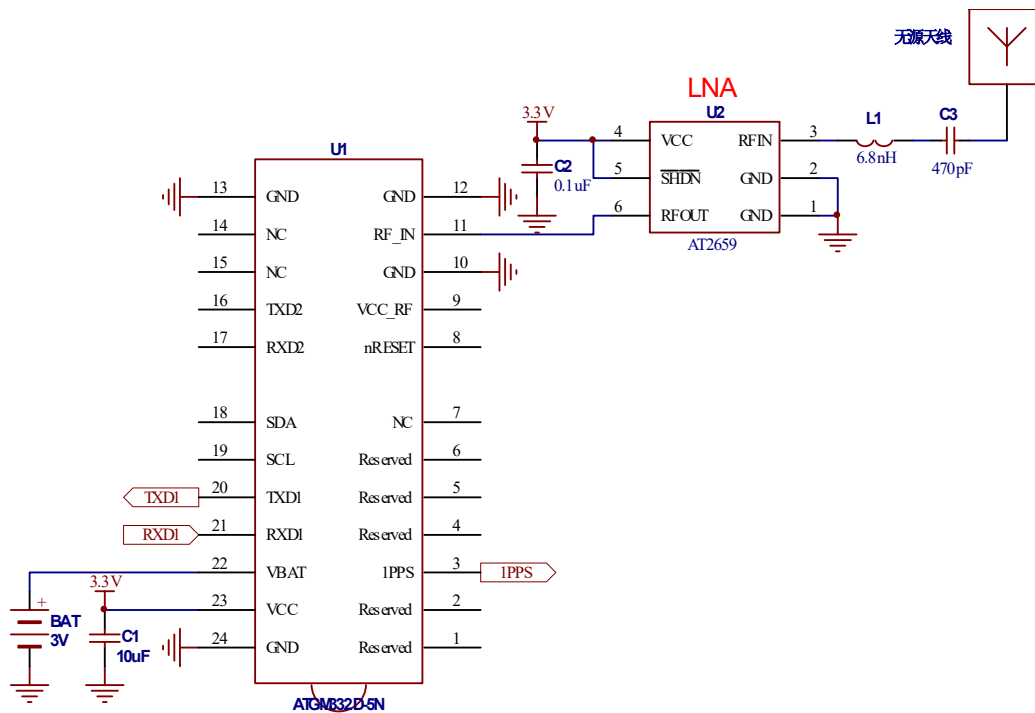

2.8 Module Application Note

In order to give full play to the excellent performance of ATGM332D-5N, users need to



pay attention to the following points when using this module:

- Low ripple LDO power supply, the ripple control within the 50mVpp.
- Module try not to go near other high frequency, large amplitude of digital signals.

All the modules below are filled with ground wire.

- The antenna interface is as close as possible to the RF input pin of the module, and pay attention to 50 ohm impedance matching.

- The module itself has the active antenna access, pull out, short circuit detection circuit, while in the antenna accidental short circuit, to limit the power supply current (50mA) and play the role of protection. In the above 3 kinds of antenna port state changes, you can output the corresponding information from the serial port. Such as :

```
$GPTXT,01,01,01,ANTENNA SHORT*63
```

```
$GPTXT,01,01,01,ANTENNA OPEN*25
```

```
$GPTXT,01,01,01,ANTENNA OK*35
```



3 Reliability Testing and Certification

3.1 RoSH Certification

ATGM332D-5N series of modules are in line with the RoSH certification.

4 Module Transfer and Welding

4.1 Module Packaging

ATGM332D-5N series of modules use vacuum roll tape for packaging, with moisture-proof, anti-static and other characteristics. The using process is compatible with the industry's major patch machines. According to the 1000 pieces of each plate for packaging. The size of the specific tape is as follows:

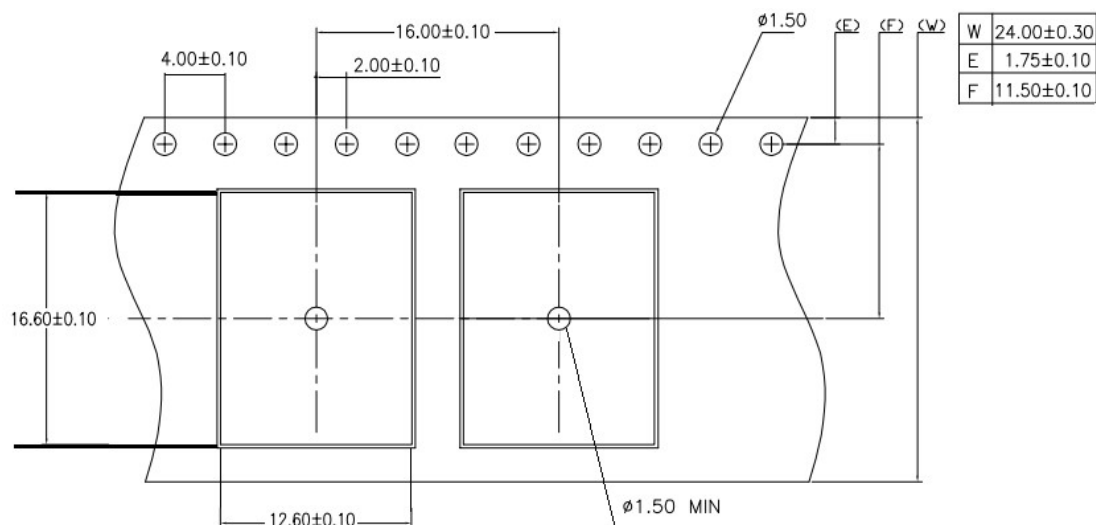



4.2 Module Transfer and Storage

4.2.1 Moisture Level:

Moisture Sensitivity Level (MSL): 4

MSL : Please refer to J-STD-020 IPC/JEDEC standard.

4.2.2 Reflow soldering curve:

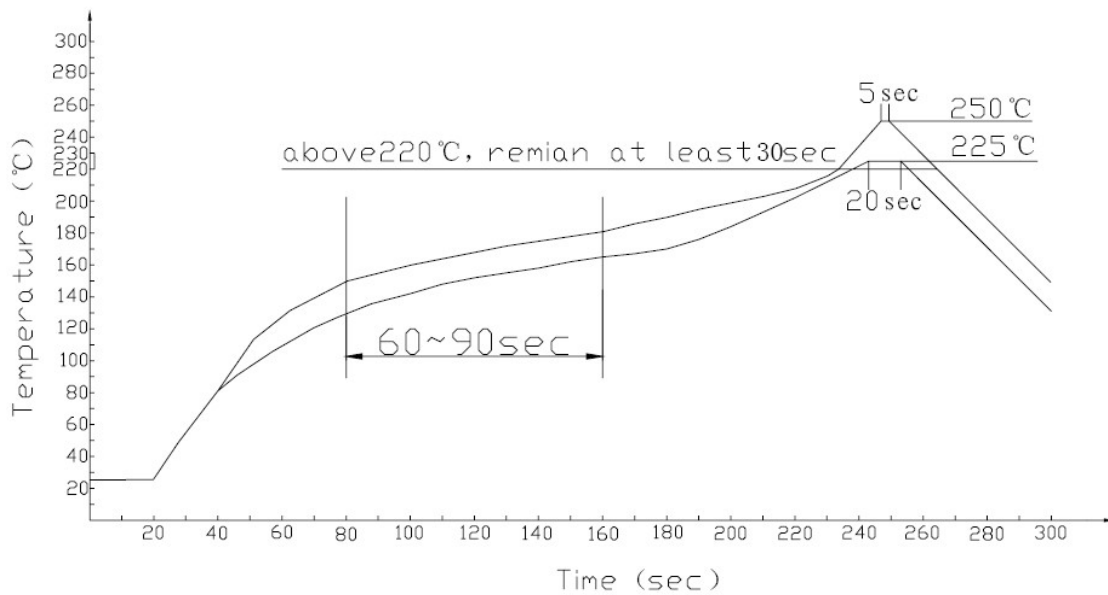

! Attention

Adjust the balance time to ensure reasonable treatment of gas when the solder melts . If there is too much space on the PCB board, it can increase the balance time. Considering the product for a long time placed in the welding area(temperature above 180 °C), in order to prevent damage to the components and floor, should be shorten the placed time as far as possible.

! The important feature of the curve:

Rise speed =1~4°C /sec, 25°C to 150°C average

Preheat temperature =140°C to 150°C, 60sec~90sec

Temperature fluctuations =225°C to 250°C, about 30sec



Fall speed = 2~6°C/sec, to 183°C, about 15sec

Total time = approximately 300sec

4.2.3 Electrostatic Protection:

ATGM332D-5N series of module is an electrostatic sensitive device. Regular electrostatic contact can cause accidental damage to the module. In addition to operating according to the standard ESD protection requirements, the following points should be as follows:

- 1) Unless GND PCB is well grounded, otherwise the first position of the contact module should be GND PCB.
- 2) When connecting the antenna, please first connect the GND, and then the signal line.
- 3) When contact with the RF circuit, please don't contact charging capacitor, please stay away from devices and equipment that can generate static electricity, such as dielectric antenna, coaxial wire, electric iron, etc.
- 4) To avoid the charge discharge through the RF input, please don't touch exposed part of antenna medium. For the touching exposed part of antenna medium that may appear, need to add the esd protection circuit in the design.
- 5) When welding the connector or antenna which is connected with the input end of the RF, be sure to use no static welding torch.

5 Module Label and Order Model

5.1 Module Label

ATGM332D-5N label contains important product information, the label content format is as follows:

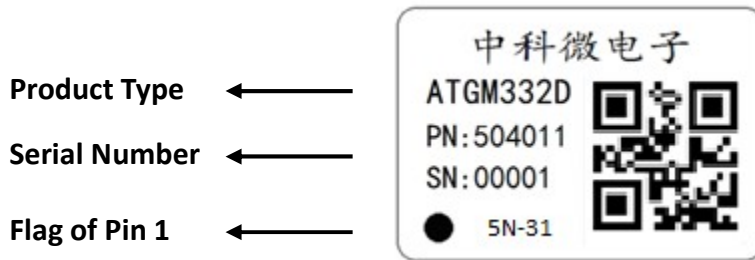

5.2 Model Naming Rules:

Example:

Field	Example	Explanation
Product code Product name	ATGM332D	12mmX16mm module series
Type code Type name	5N	Navigation module using AT6558 hardware platform
Hardware code Hardware function name	31	With functions of GPS + BDS Hardware Version = 1 versions of Hardware
Software code Software function name	0	Standard software function version

5.3 General Order Model

General Order Model	Product
ATGM332D-5N-11-0	12X16 Size, AT6558 Chip, Navigation module, GPS positioning, 16.369M Crystal oscillator, standard output
ATGM332D-5N-21-0	12X16 Size, AT6558 Chip, Navigation module, BDS positioning, 16.369M Crystal oscillator, standard output



ATGM332D-5N-31-0	12X16 Size, AT6558 Chip, Navigation module, GPS+BDS positioning, 16.369M Crystal oscillator, standard output
ATGM332D-5N-51-0	12X16 Size, AT6558 Chip, Navigation module, GPS+GLONASS positioning, 16.369M Crystal oscillator, standard output
ATGM332D-5N-71-0	12X16 Size, AT6558 Chip, Navigation module, GPS+BDS+GLONASS positioning, 16.369M Crystal oscillator, standard output

5.4 Custom order model:

The Zhongke micro modules provide software customization services to domestic customers. Specific mode of cooperation and naming of product orders , please contact the sales representatives.

Reference

1. "ZKMicro AGNSS solutions"
2. "CASIC multi mode satellite navigation receiver protocol specification"
3. "ATGM module online upgrade protocol "
4. "AT6558 datasheet (EN) "
5. "GNSSToolKit tool instructions"
6. "UBF serial port upgrade tool instructions"