



High-quality, license-free, ultra-tiny VTX

Revision 2024-08-15

The **TBS UNIFY PRO32** is a successor to the most popular line of video transmitters (TBS UNIFY PRO). We have improved the robustness, decreased the size and power consumption, added capability for insane features, and perfected the way it is installed in your multicopter. In a nutshell, it's the most comprehensive, future-proof, highest quality, and overall best VTX line made to date.

Key features: Main features across all Unify Pro32 models

- World's lightest 37ch video transmitter line (custom channels via SmartAudio and CRSF)
- Power to Channel calibration for each channel - extremely consistent output power
- 25mW (more power available, requires HAM license*)
- One button frequency and power setup
- OSD configuration using TBS SmartAudio 2.1 (via FC, TBS Crossfire/ Tracer or PNP PRO OSD)
- LUA support for CRSF users
- U.FL connector (Unify PRO32 nano)
- MMCX connector (Unify PRO32 HV)
- 1-3S input or 2-6S input with 5V output versions available
- Improved noise filtering
- Double noise filtering (Unify PRO32 HV)
- Optimized heat dissipation
- Solder-on module dimensions available on request



TEAM BLACKSHEEP
SERIOUS TOYS



Table of Contents

[Table of Contents](#)

[Specifications](#)

[Attention](#)

[FAQ](#)

[Important Note for the Pro32 DP:](#)

[Updating](#)

[Overview](#)

[Button menu control](#)

[Unlock & power select mode](#)

[Button menu structure](#)

[Menu Table](#)

[Channel/ Band - Frequency Table](#)

[Installation / Mounting](#)

[Pinout](#)

[TBS UNIFY PRO32 5G8 nano](#)

[TBS UNIFY PRO32 HV 5G8](#)

[TBS UNIFY PRO32 DP](#)

[Control by Flight Controllers \(SmartAudio\)](#)

[Control by Crossfire/ Tracer direct connection](#)

[Crossfire/Tracer connection using SmartAudio](#)

[Crossfire/Tracer connection using CRSE](#)

[Smart Audio or CRSE for the VTX?](#)

[Button not working](#)

[Control by PWM channel \(Unify PRO32 Nano only\)](#)

[Barcode Control](#)

[Technology showcase](#)

[PITMode](#)

[SmartAudio 2.1](#)

[CRSE](#)

[CleanSwitch](#)

[Force the device into bootloader mode](#)



Specifications

	TBS UNIFY PRO32 5G8 nano	TBS UNIFY PRO32 HV (MMCX) / PRO32 DP
Input voltage:	1S - 3S LiPo/ 3V - 13V	2S - 6S LiPo/ 6V - 36V
Power Output	Input Voltage - LC filter - Output voltage (pass through, following input voltage)	Regulated and filtered 5V / 2A
Extra features:	CleanSwipe PITMode (incl. Support for team racing) Full CRSF capability (Serial commands for external control)	
Software protocol	SmartAudio V2.1 CRSF	
Output Power	14dBm (25mW) 20dBm (100mW*) 26dBm (400mW*) 28dBm (600mW*) (Rev 1.1)	14dBm (25mW) 20dBm (100mW*) 26dBm (400mW*) / 200mW** 30dBm (1000mW*) / 400mW** 27dBm/ 500mW** / 999 mW** / Max**
Pit mode	<p>Activate: Press power during startup or use Smart Audio V2.1 LED flashes red when enabled</p> <p>Disable / Deactivate: Press power for 5 seconds during runtime Or use Smart Audio V2.1</p>	
Pit mode -> flight mode	On-board button, SmartAudio 2.1, or CRSF Command	
Channels:	Band A, B, E, Fatshar, Race Band, <u>M, H, Y, T</u> **8ch	
Audio on 6.5MHz	No	Yes, built-in Microphone / No
Power consumption	25mW: 210mA 400mW: 390mA	25mW: 90mA - 130mA (22V - 14.8V) 1000mW+: 300mA - 450mA (22V - 14.8V) PRO DP32 MAX: up to 1,8A
Range:	2km (omni)	6km (omni)
Antenna connector:	u.FL high strength	MMCX
Port connector	Through-holes, 2mm pitch	JST-GH 7 pin
Dimensions:	14.5(L) x 13(W) x 3(H) mm	37(L) x 25(W) x 6(H) mm
Weight:	1g	9.2g/ 8.7g
Firmware upgrade	No	Yes / No
Kit contents:	TBS UNIFY PRO32 NANO u.FL Antenna Silicon Cables pre- tinned	TBS UNIFY PRO32 / PRO32 DP MMCX to SMA Pigtail JST-GH 7pin Silicon Cable ends pre-tinned

* requires HAM license, special unlocking procedure, available on selected models only, except PRO32 DP

** PRO32 DP only



Attention

These video transmitters can transmit radio frequencies and output power that may not be allowed in your country.

Please always check your local RF legislation to set the frequency and output power according to the regulation.

A general rule for RC aircraft is that they must always be controlled under sight of view, so check your RC regulations to keep up to date with them.

FAQ

If you have any questions after reading this manual, you should visit the [TBS FAQ](#) section.

Important Note for the Pro32 DP:

Please do not plug/unplug your MMCX connector too often unless necessary. They are rated to 50 cycles max!

The DP has high requirements for the antennas used. It will not survive antennas that have a VSWR beyond the following specs: Between 5.6 - 6GHz, VSWR > 1.8. Between 5.0 - 5.6GHz, VSWR > 2. Please note that this includes pigtailed or extension cables, typically having a VSWR between 1.1 and 1.2.

As we have no insight into readily available antennas on the market, we recommend to only use TBS-branded antennas connected directly to the VTx port. In the case of using pigtailed, we recommend limiting to the 2W power setting in anything but well-controlled cases (using TBS antennas and TBS pigtailed)

Updating

To update your Unify32 (not Nano32), you need the TBS AGENT Web/ Desktop, which you can download from the [TBS shop](#).

To update your VTX, connect it to the USB port and run the update by AGENT Web/ Desktop.

Overview

Nano32



Pro32



DP

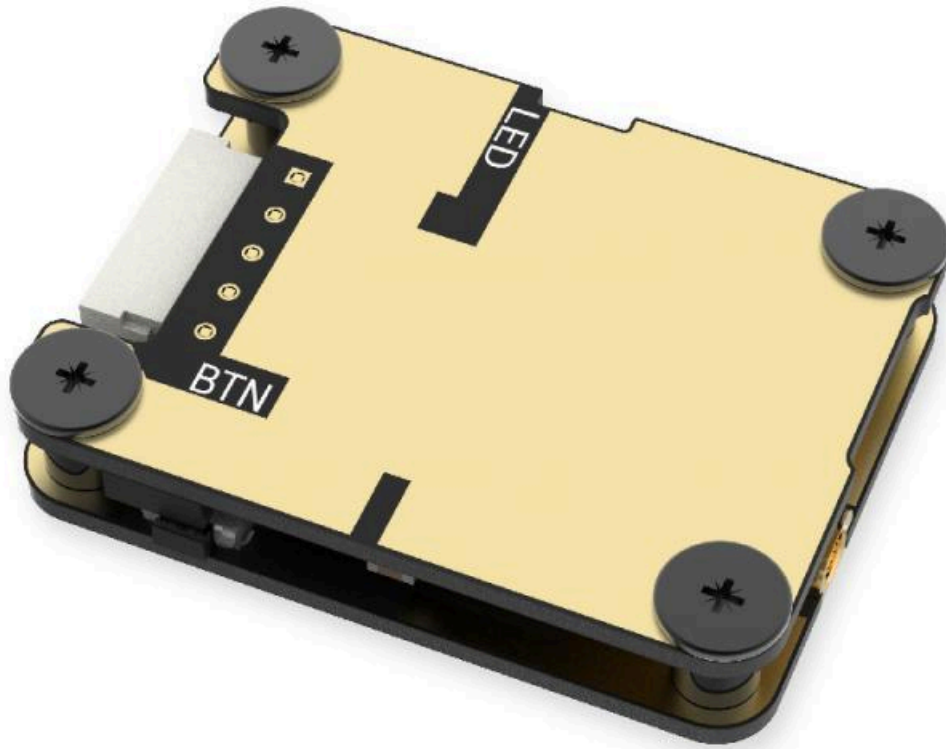

The Unify Pro32 DP does not have a USB port!

IMPORTANT!

The DP has high requirements for the antennas used. It will not survive antennas that have a VSWR beyond the following specs: Between 5.6 - 6GHz, VSWR > 1.8. Between 5.0 - 5.6GHz, VSWR > 2. Please note that this includes pigtails or extension cables, which typically have a VSWR between 1.1 and 1.2.

As we have no insight into readily available antennas on the market, we recommend to only use TBS-branded antennas connected directly to the VTx port. In the case of using pigtails, we recommend limiting to the 2W power setting in anything but well-controlled cases (using TBS antennas and TBS pigtails)

We recommend to use the TBS Airscrew antenna with the PRO32 DP -[get yours at TBS](#)



Button menu control

The menu consists of categories and settings. Pressing the button for 3 seconds toggles between categories, and pressing it for a short time toggles between settings. To enter the menu, hold the button for 3 seconds. LED colors signal the state of the menu. For an overview, see the [menu table](#).

Unlock & power select mode

(FOR HAM USERS ONLY!) Press the button for about 30 seconds. The Red LED will flash 3 times to confirm. You have unlocked the video transmitter for use with all frequencies (see frequency table below).

NOTE: Unlock only works if you are inside the band selection menu

The power select mode is now accessible. Once unlocked, you can select the power level according to the table below. To lock the transmitter, return to the band, select menu, and press the button for 20 to 25 seconds again.

Button menu structure

For Unify PRO32 HV

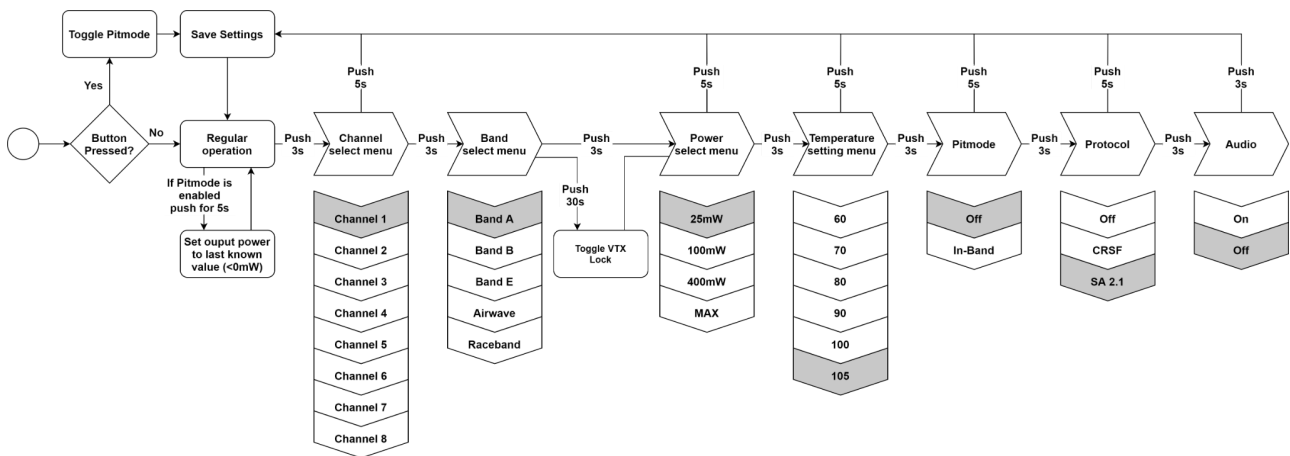

For Unify PRO32 Nano

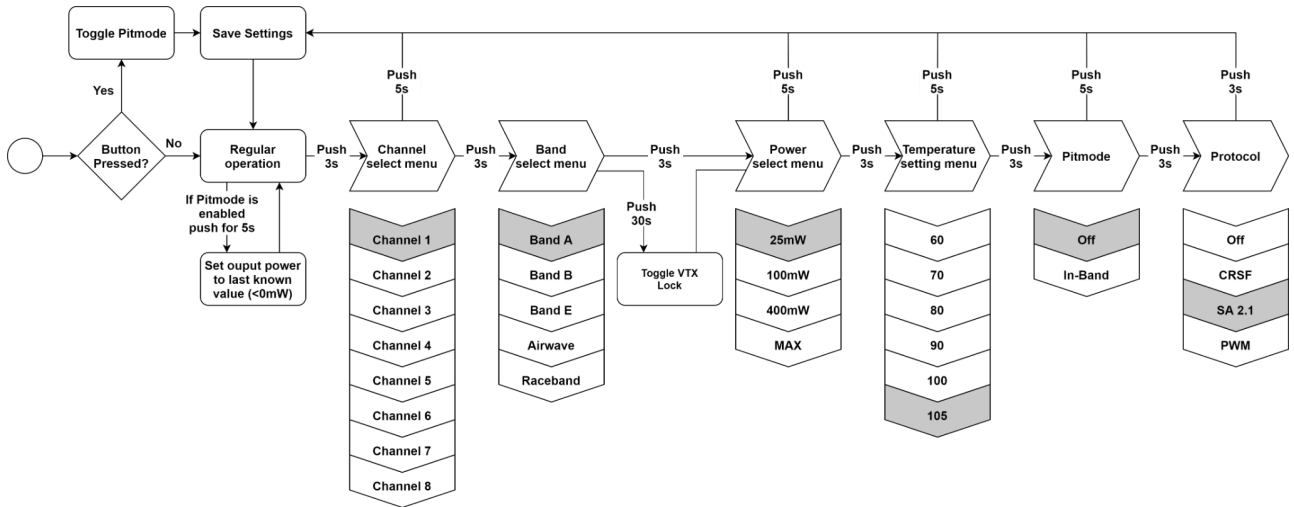

For Unify PRO32 DP

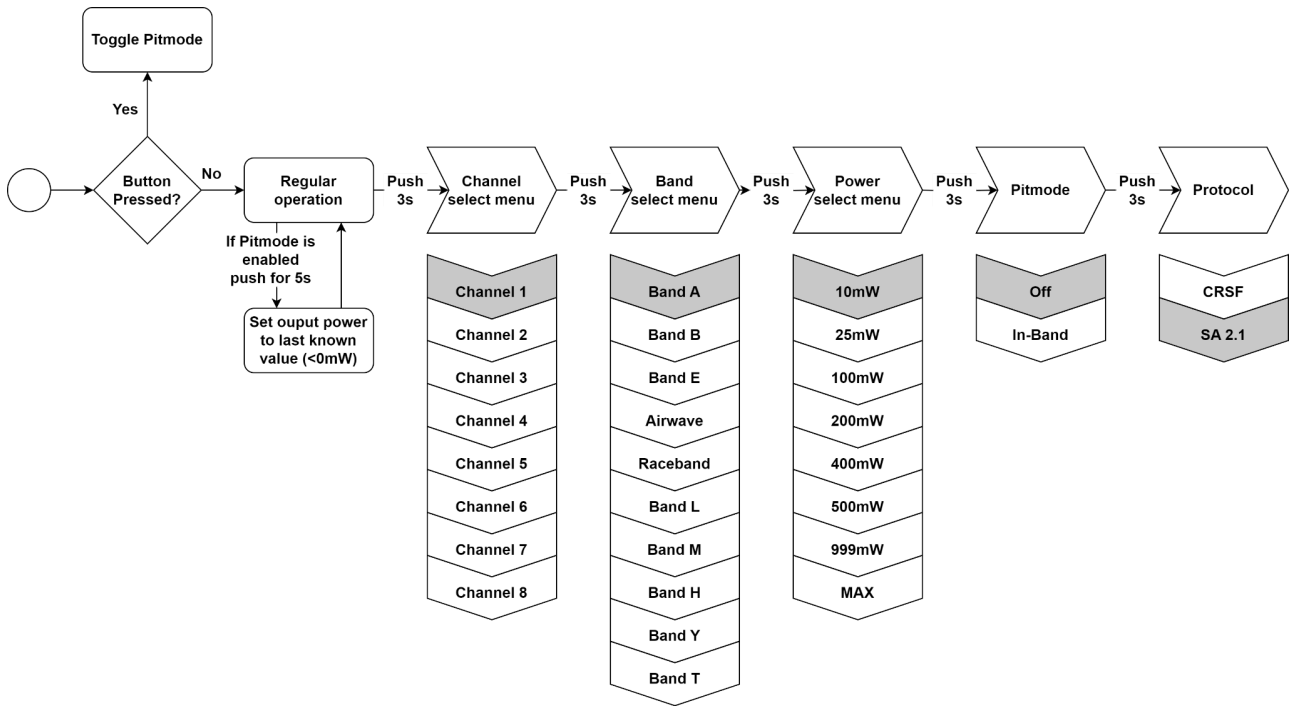

The TBS UNIFY PRO32 5G8 signals selected channel, band, and power levels using a startup sequence of LED codes. The same sequence is also repeated in the menu to make it unified. First, the **RED** LED flashes to indicate the item being shown. One flash for the channel, two flashes for the band, three flashes for power level. Subsequently, the **BLUE** LED will indicate the value.

Red LED:	Indicate item - Channel, band, or power setting
Blue LED:	Indicate value

Menu Table

RED LED		BLUE LED							
		1x	2x	3x	4x	5x	6x	7x	8x
1x	Channel	1	2	3	4	5	6	7	8
2x	Band	A	B	E	Airwave	Race			
3x	Power Level	25mW	100mW	400mW	1000mW				
4x	Limit Temp.	60	70	80	90	100	105		
5x	PIT Mode	OFF	IN-BAND						
6x	CRSF/SA/PWM	OFF	CRSF	SA	PWM**				
7x*	Audio (Mic)	OFF	ON						

* Unify PRO32 HV only

** Unify PRO32 Nano only

Power levels differ for the PRO32 DP, please check the [menu overview](#) for details



Channel/ Band - Frequency Table

Channel	1	2	3	4	5	6	7	8	
Band A	5865	5845	5825	5805	5785	5765	5745	5725	MHz
Band B	5733	5752	5771	5790	5809	5828	5847	5866	MHz
Band E	5705	5685	5665	5645	5885	5905	5925	5945	MHz
Airwave	5740	5760	5780	5800	5820	5840	5860	5880	MHz
Race Band	5658	5695	5732	5769	5806	5843	5880	5917	MHz
Power Level	25	100	400	1000+					mW

Grey fields are the default factory setting.

The selections in orange require a HAM license to operate legally. Black selections are only available on special requests (custom firmware for large events with prior legal body approval). The video transmitter ensures that you cannot select illegal channels or power levels by accident:

- When controlled by the push button, you will need to confirm having a HAM license by following the steps described above to unlock your video transmitter
- Through the CORE PRO, you are required to enter your HAM license number under the “Callsign” menu before you can access the high-power transmission settings and the locked-out channels



PRO32 DP

Channel / Band – Frequency Table

Channel	CH1	CH2	CH3	CH4	CH5	CH6	CH7	CH8	
A	5865	5845	5825	5805	5785	5765	5745	5725	MHz
B	5733	5752	5771	5790	5809	5828	5847	5866	MHz
E	5705	5685	5665	5645	5885	5905	5925	5945	MHz
F	5740	5760	5780	5800	5820	5840	5860	5880	MHz
R	5658	5695	5732	5769	5806	5843	5880	5917	MHz
LoR	5362	5399	5436	5473	5510	5547	5584	5621	MHz
M	5658	5678	5717	5737	5835	5855	5894	5914	MHz
H (X)	4990	5020	5050	5080	5110	5140	5170	5200	MHz
Y	4991	5045	5097	5128	5329	5435	5477	5590	MHz
T	5176	5261	5323	5360	5946	5974	6013	6030	MHz

The PRO32 DP does not come with any channels or power levels locked!



Installation / Mounting

When installing the Unify Pro32, please ensure adequate airflow and - most importantly - heat transfer. This means mounting the Unify Pro32 with some pressure against a flat piece of carbon will give you the best results. Make sure to isolate the contacts of the Unify against the carbon to avoid short circuits. Proper mounting will allow the video transmitter to run for extended periods of time while sitting on the ground and without reducing output power. TBS UNIFY PRO32 automatically reduces output power before it reaches critical heat levels.

Pinout

TBS UNIFY PRO32 5G8 nano

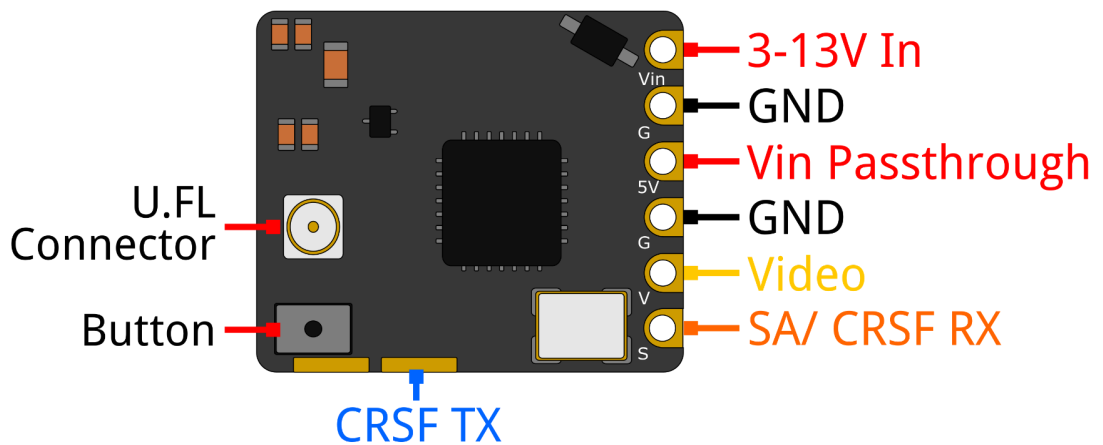

The UNIFY PRO32 5G8 Nano comes with pre-installed silicon wires for easy installation in your build. It has a filtered 3-13V input with a pass-through output for your camera or other devices.

ATTENTION!

- Please take care when soldering to the tabs; do not solder with temperatures higher than 350°C for more than 3-5sec.
- For remote control of the VTX channels we suggest using SmartAudio or CRSF interface. The tactile button is very fragile, do not use hard and pointy objects such as needles to change channels to prevent permanent damage to the button.
- If you plan to use the VTX on 13v, make sure to use proper filtering, as any voltage spike will damage it.



TBS UNIFY PRO32 HV 5G8

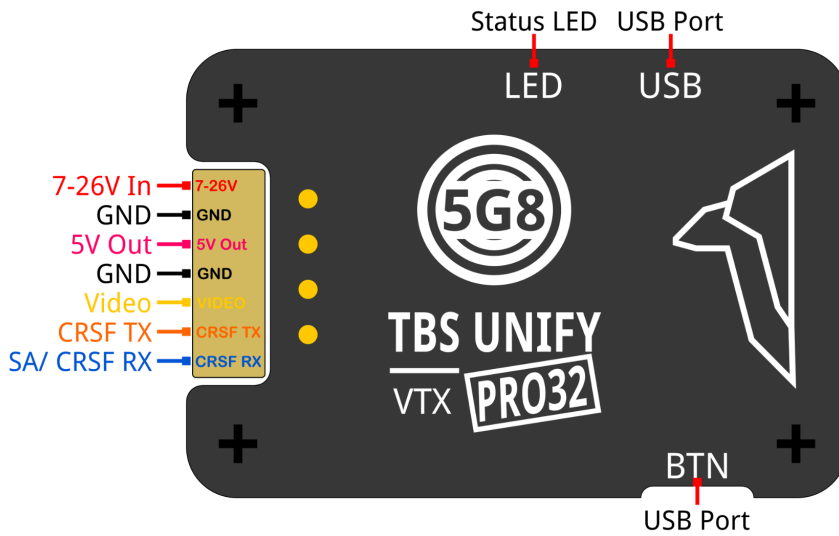

TBS UNIFY PRO32 DP

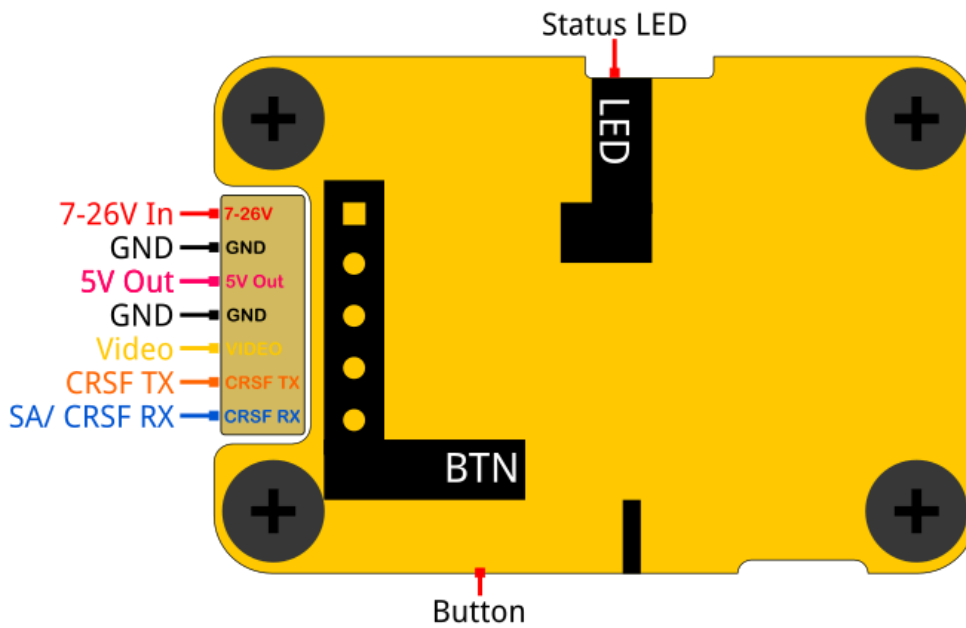

The UNIFY PRO32 5G8 HV/ DP got a cable assembly with silicon wires for easy installation in your build. There is a filtered 5V output for your camera.

The installed Step-Down converter is a new, more powerful DCDC capable of powering most 5V cameras on the market.



Control by Flight Controllers (SmartAudio)

Using any Smart Audio V2.1-compatible flight controller, simply connect the Smart Audio data pin to a free and supported port on your FC (see pinout below).

For Betaflight users, you can then configure the connected port in the Betaflight configurator to the Smart Audio V2.1 protocol. Ideally, you get a Betaflight firmware that supports the new SA2.1 (Betaflight >=V3.5.6) rather than the older SA2.0. This way, you get access to the new power levels of SA2.1.

If you use BF 4.xx or later, you need to add the VTX table. You can download the VTX tables for all TBS UNIFY VTXs [here](#).

Control by Crossfire/ Tracer direct connection

Your TBS Crossfire/ Tracer can control your TBS Unify Pro32 directly without needing an FC. This is helpful when you don't have an FC in your aircraft, have no free UART left, or just don't want to control the Unify32 without any extra setup required.

Visit the Crossfire or Tracer manuals for details on how to set them up.

Crossfire/Tracer connection using SmartAudio

You can connect your Unify Pro32 to any Crossfire/ Tracer receiver. The VTX will then be controlled by Agent Lite by the *Video TX* menu or in the VTX menu of the receiver:

- Set the Unify to SmartAudio by the button
- Select a free output pin capable of SA
- Connect them (Crossfire/ Tracer SA TX to VTX RX/ SmartAudio pad) Crossfire/Tracer connection using SmartAudio

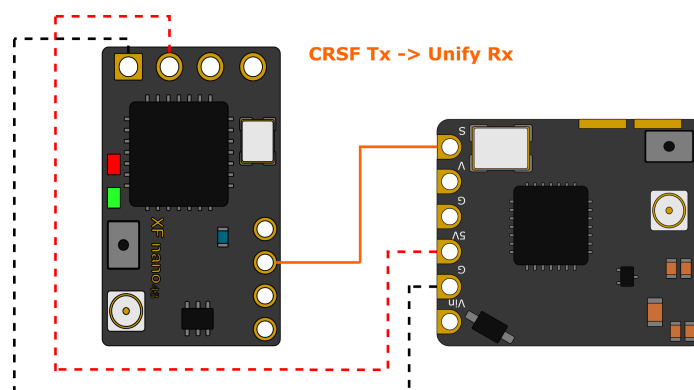

Wiring example

Now you can control your Unify using the VideoTx menu or the VTX menu of the receiver by Agent Lite, etc.

Crossfire/Tracer connection using CRSF

All Unify PRO32 have a full serial interface with extended functionality compared to SmartAudio, which is just a one-wire protocol.

- Set the Unify to CRSF by the button
- Select a free output pin pair capable of CRSF
- Connect them (Crossfire/ Tracer SA TX to VTX RX/ SmartAudio pad) Crossfire/Tracer connection using SmartAudio

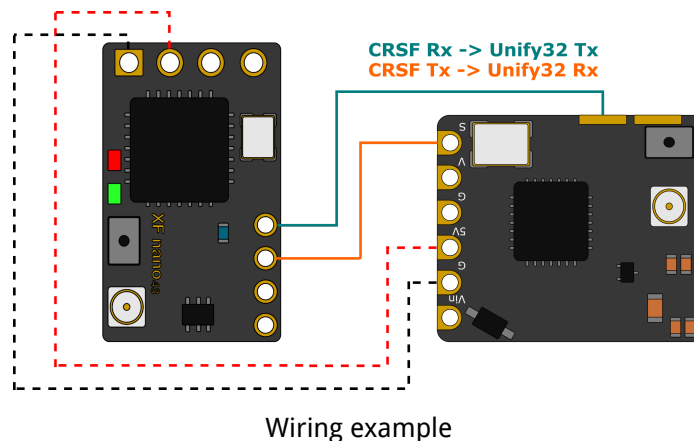

Now you can control your Unify by the My VTX menu or by its device menu by Agent lite etc.

Smart Audio or CRSF for the VTX?

Both protocols had their advantages and disadvantages:

- **SmartAudio**
 - Single wire connection. Saves one PWM output (useful on a wing)
- **CRSF**
 - Fully configurable by LUA, FUSION, AGENT M Web, etc.
 - CRSF readout - let you use PITMode on a switch or navigate through the Unify Evo OSD without the need for an FC, link stats readout with the Unify EVO OSD

Button not working

When the Unify Pro32 detects a signal on the RX pad, it will disable the button. To change the VTX to CRSF or SA, you can unsolder the wire or force your Crossfire/ Tracer RX not to output any signal.

- Set the output of the Tracer RX to CH X (PWM) for the pin the VTX is connected to
- Shut down the Tracer TX and RX
- Power up just the drone with the Tracer RX and the Unify Pro32
- Change the Unify Pro32 settings by the button
- Turn the transmitter back on
- Set the output map back to CRSF or SmartAudio

On the HV version, this can be done by the Agent M as it has a USB port

If you have set up everything correctly, you should see the Unify32 in the Lua script, Tango device menu, or the Crossfire OLED display (FW 3.21 or later required).

Control by PWM channel (Unify PRO32 Nano only)

This simplified method uses a single channel as a button to modify the VTX channel. Depending on the radio controller, you may need to reverse the channel output. Connect the PWM output from your receiver to the SmartAudio/CRSF RX pin. The operations are as follows:

- Short push the button to increase the channel.
- Long push the button (>3s) to increase the band.
- Longer push the button (>5s) to reset the VTX channel to A1.



Barcode Control

The video transmitter can be controlled via barcodes through your camera. Holding the barcode in front of your camera enables PITMode and powers up the video transmitter. You can also simply carry your favorite channel in your pocket or backpack and revert to that channel easily and quickly.

You can download a PDF barcode catalog from this link:

- <http://www.team-blacksheep.com/tbs-VTX-barcodes.pdf>

Android app:

- <https://noahwaldner.ch/en/tbs-barcode-generator>
- <https://apocolipse.github.io/UnifyEvoBarcodeGenerator/>

Raw .json file:

- <http://firmware.team-blacksheep.com/barcodes>

We are always expanding the functionality. If you have any crazy ideas for implementing barcodes for your races or other purposes, please let us know! We're happy to expand the functionality at all times!

Note: the nano32 supports barcode reading since HW version 1.1



Technology showcase

PITMode

PITMode is a mode where the video transmitter only runs on incredibly low output power. This prevents interference with others at events while still allowing a minimum of visibility for emergency last-minute setting changes.

With the TBS UNIFY PRO32 line, Pit Mode has been slightly modified in behavior. The main button on the video transmitter is used to toggle the PITMode flag at power-up, and SmartAudio / CRSF can modify this flag as well. Smart Audio can also enter pit mode during runtime using the power setting 0mW, which will not modify the flag (the VTX will never power up at the 0mW power setting). To leave PITMode during operation, simply set your desired power setting using Smart Audio, CRSF, or the button menu.

SmartAudio 2.1

SmartAudio is a protocol developed by TBS for OSD to VTX communication. SmartAudio is a single-wire UART protocol, running over the (Audio)-wire. All newer generation OSDs at TBS and all UNIFY PRO series VTX, and all modern flight controllers support SmartAudio!

With the UNIFY PRO32 line, we have launched SmartAudio V2.1. Over the regular SmartAudio, it changed control for PITMode in operation to a switch(on / off) rather than a flag that is refreshed on reboot.

If you are an OSD or VTX developer interested in adding support for SmartAudio, please check our [SmartAudio specification](#). SmartAudio is a free-to-use protocol. If you'd like to use "TBS SmartAudio" in your marketing, you may contact us for licensing options:

- <http://team-blacksheep.freshdesk.com/>

CRSF

CRSF is a protocol designed by Team BlackSheep and championed through the TBS Crossfire remote control system. It has been integrated into the most popular remote controls is an incredibly high bandwidth (low latency) full-duplex, serial data transmission protocol. It has native functionality such as OTA (over-the-air) firmware upgrades, localized configuration menus, and a smart routing protocol.

With the advent of the TBS UNIFY PRO32, for the first time in FPV history a VTX now supports this functionality. We can configure the channel, output power, and PITMode settings.

CleanSwitch

A new feature introduced with the TBS UNIFY PRO 5G8 is CleanSwitch. When video transmitters power up or change frequency, they usually send a burst across the entire band which disturbs fellow flying pilots. All UNIFY PRO32 5G8 video transmitters will remain in their lowest power output (less than 0.1mW) while changing channels and powering up. This ensures interruption-free racing, even with multiple video transmitters changing channels or powering up. Despite all this, TBS UNIFY PRO & EVO are still the fastest video transmitter on power-up - thus ensuring it is the perfect choice for any application where quick channel changes are a necessity!



Force the device into bootloader mode

In rare cases, forcing the device into bootloader mode can be required. This can be done by simply bridging 2 pads on the unit and then powering up. However, it will not be required for regular operation.

Please follow the diagram below:

- TBS Unify Pro32 HV (MMCX)

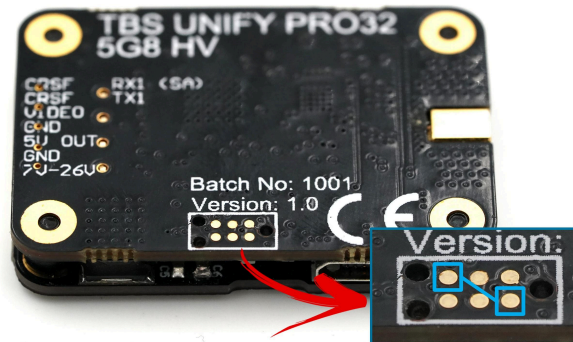

- TBS Unify Pro32 Nano

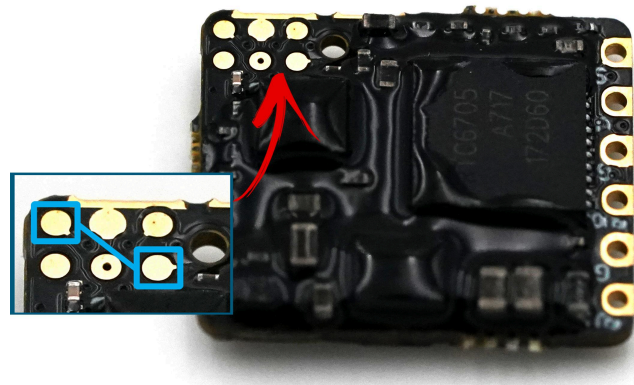

Manual designed by ivc.no, written by TBS, ivc.no, and kamikatz-fpv.de

