

HARRIER S1100

WARNING!
This product is NOT a toy, Adult supervision is required for those under 14 years old.

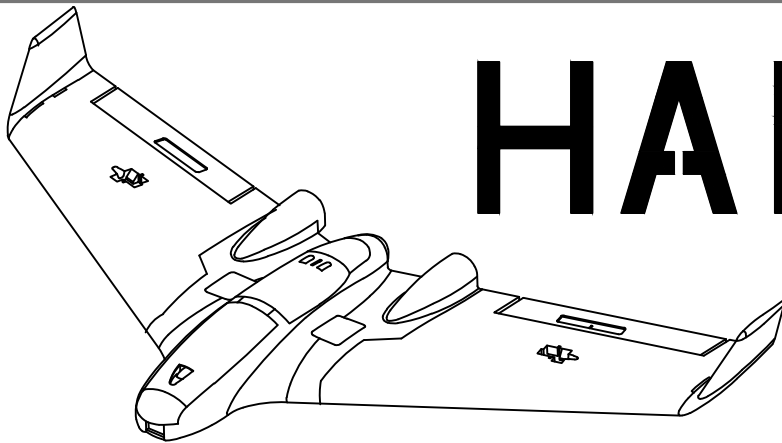

WARNING: Read the ENTIRE instruction manual to become familiar with the features of the product before operating. Failure to operate the product correctly can result in damage to the product, personal property and cause serious injury. This is a sophisticated hobby product. It must be operated with caution and common sense and requires some basic mechanical ability. Failure to operate this Product in a safe and responsible manner could result in injury or damage to the product or other property. This product is not intended for use by children without direct adult supervision.

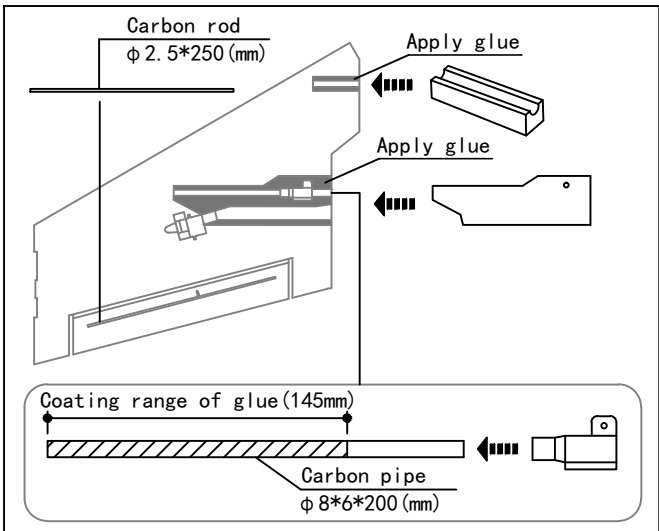

Installation mode of carbon tube for wing.

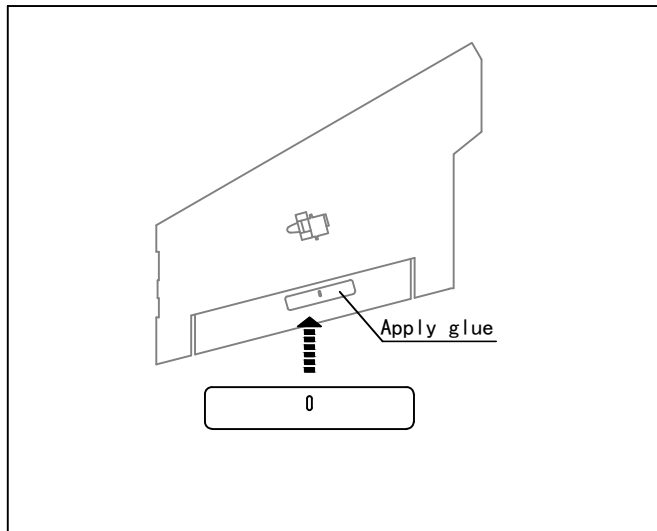

The installation mode of the aileron carbon sheet.

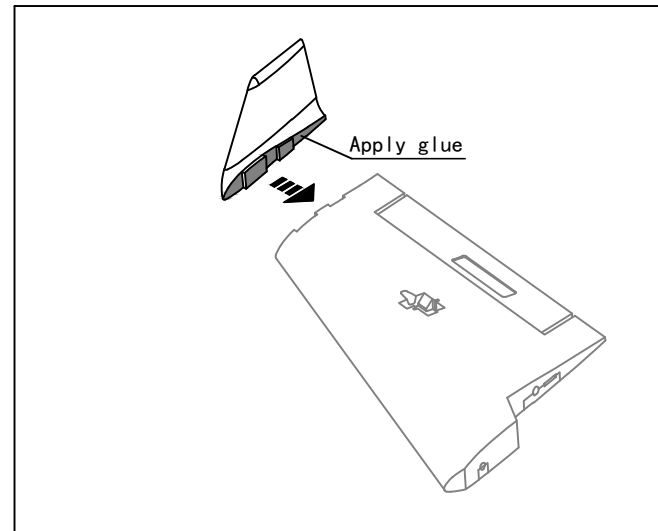

The winglet sticky on the wing.

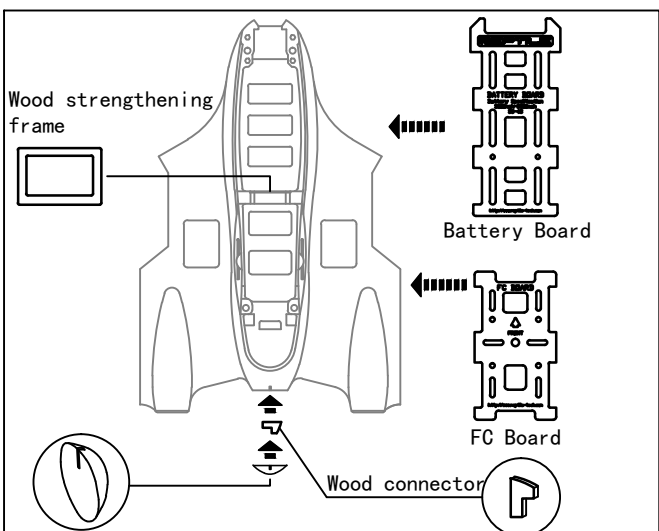

Installation mode of engine room equipment board.

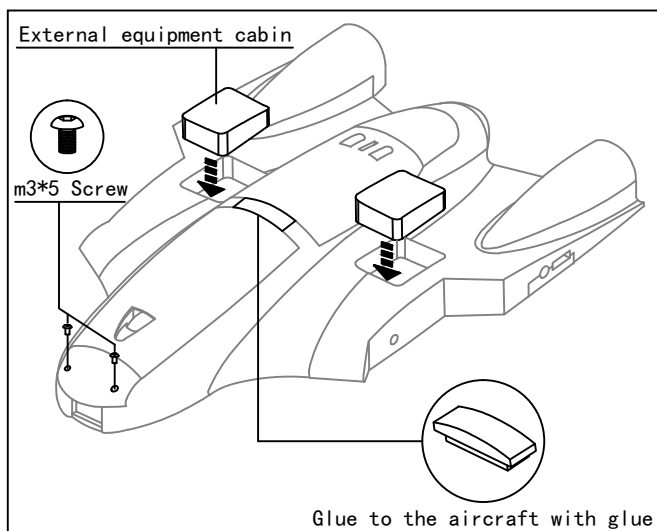

Glue to the aircraft with glue

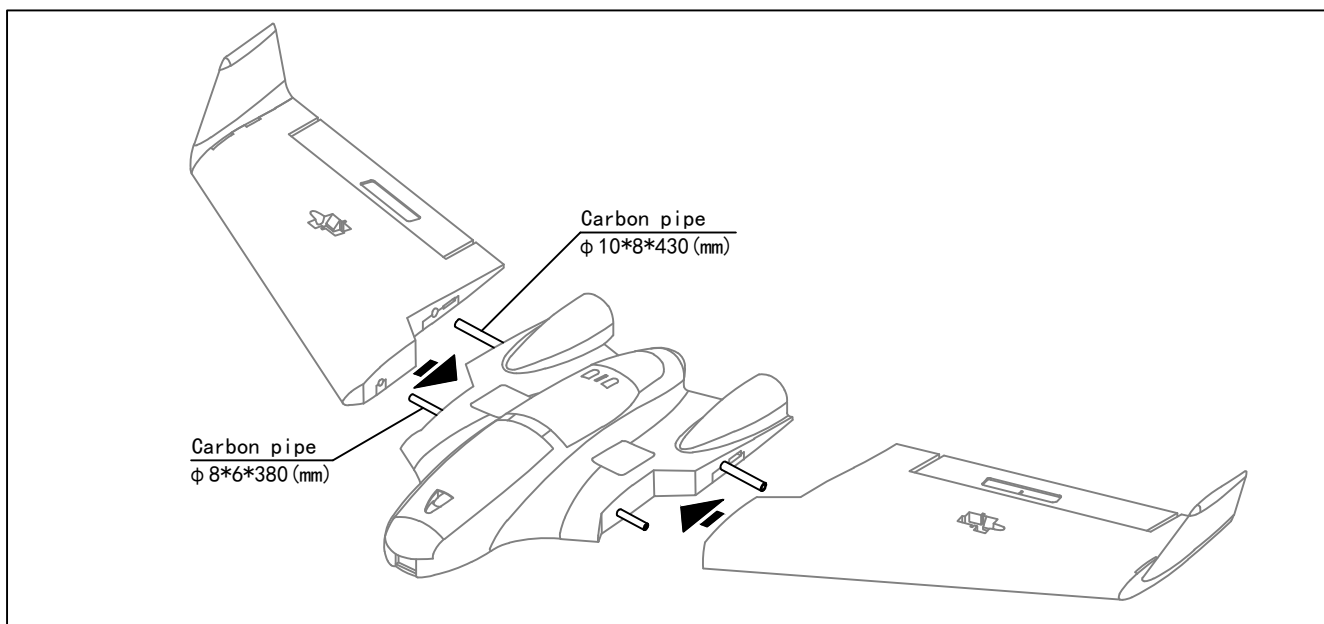
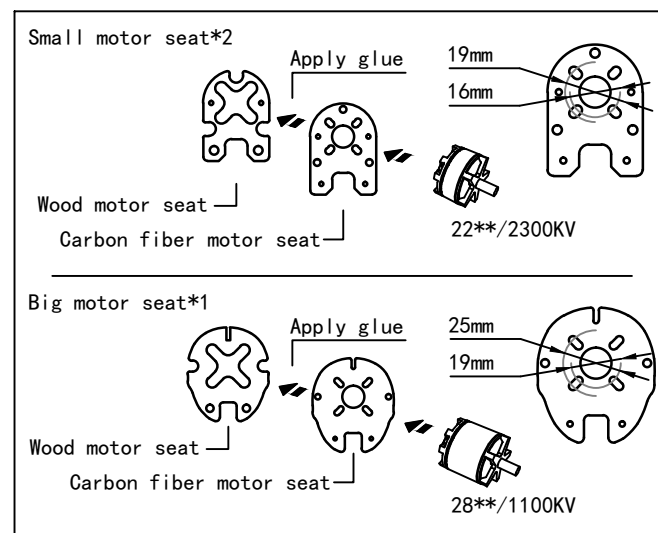
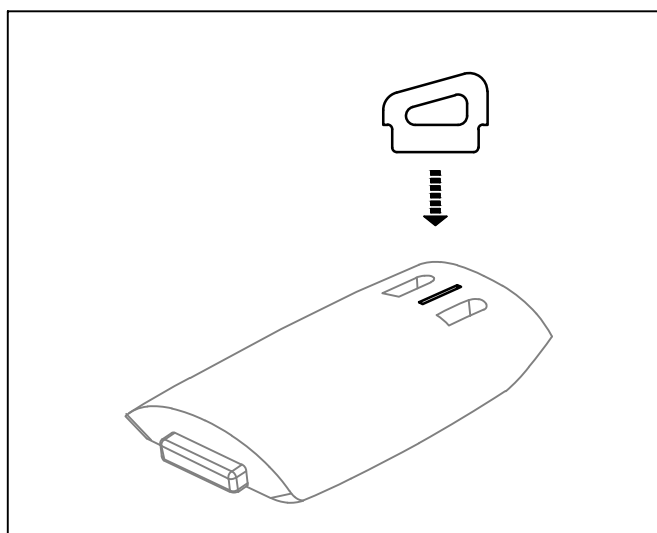
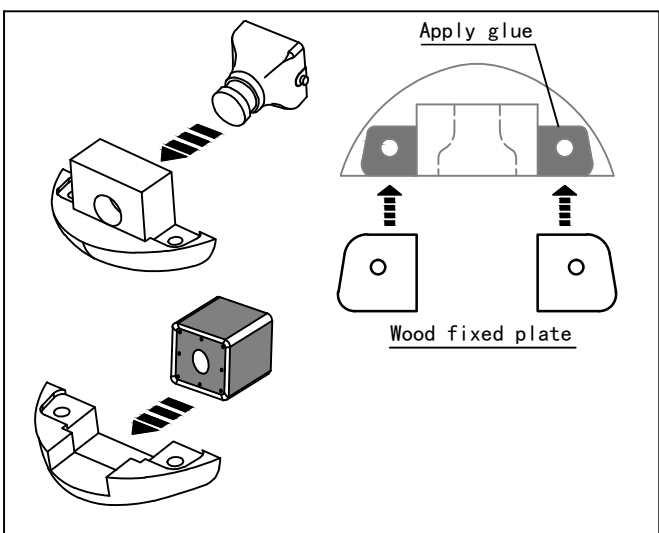
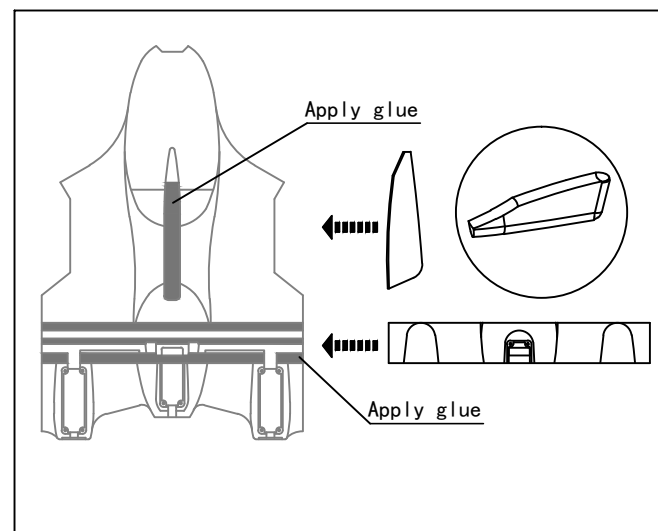

Carbon tube links for airframe and wing.
The airframe and the wing are locked by the plastic pipe clamp.

CG
285mm BEHIND THE HEAD

