

RunCam Night Eagle 3

USER MANUAL

Joystick Control

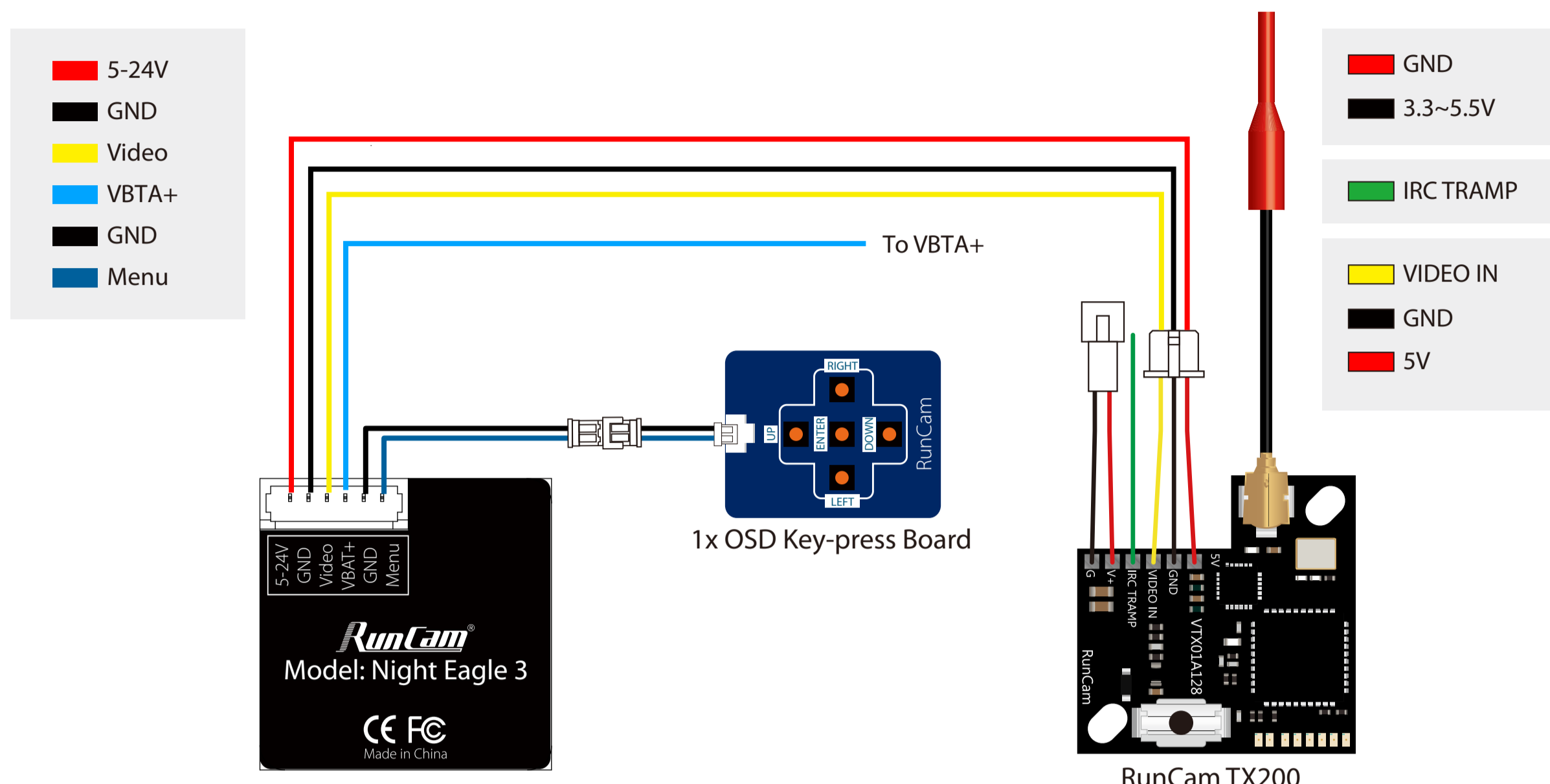

Dimensions & Installation

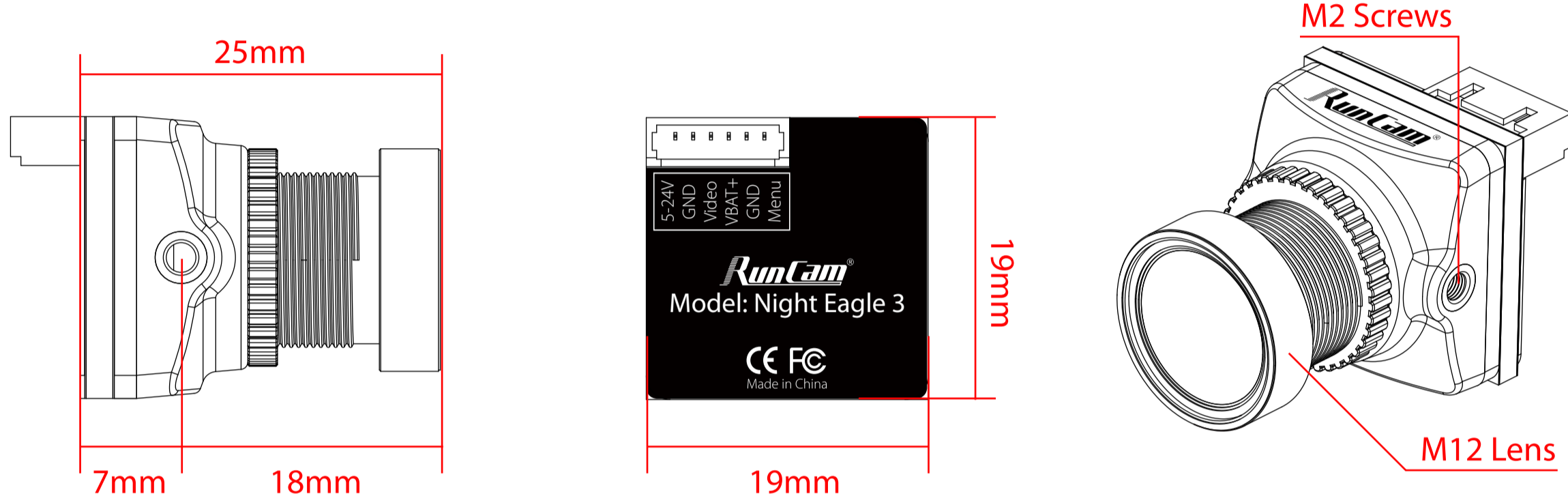

Camera Menu

MAIN MENU		
EXPOSURE		←
DAY&NIGHT		←
COLOR		←
DNR		LOW
IMAGE		←
SYSTEM		←
EXIT		

EXPOSURE		
BRIGHTNESS		◀ 10 ▶
SHUTTER		◀ AUTO ▶
AGC		10
RETURN		

DAY NIGHT		
MODE		◀ AUTO ▶
D>N THRES	13	
N>D THRES	7	
DELAY		LOW
RETURN		←

COLOR		
AWB		◀ AUTO ▶
COLOR GAIN	10	
COLOR ADJ		←
RETURN		←

IMAGE		
SHARPNESS	4	
GAMMA	0.45	
MIRROR		OFF
FLIP		OFF
RETURN		←

SYSTEM		
PILOT		OFF
TIMER		ON
VOLTAGE		ON
SYSTEM	N/P	NTSC
SCREEN		16:9
LANGUAGE		ENG
RESET		ON
RETURN		←

Parameters

Model	RunCam Night Eagle 3	
Image Sensor	1/2.8"2MP	
Horizontal Resolution	1000TVL	
Lens	FOV D:125° H:107° V:56°	FOV D:97° H:75° V:56°
Screen Format	16:9	4:3
Signal System	NTSC / PAL Switchable	
Integrated OSD	Yes	
Mirror/Flip	Available	
S/N Ratio	>50dB	
Electronic Shutter Speed	Auto	
Sensitivity	11390 mV/Lux-sec	
Day/Night	Black & White	
Menu Control	Joystick Control	
Power	DC 5-24V	
Current	90mA@12V / 250mA@5V	
Housing Material	ABS	
Net Weight	8.5g	
Dimensions	L19mm*W19mm*H25mm	