

# HUBOSD eco X-Type

## w/STOSD8, CURRENT SENSOR, DUAL BEC & XT60

SKU: HUBOSD8-X

The HUBOSD8 has been engineered to provide the highest possible performance and reliability in a 46\*36mm & 4 layers PCB. It is a multifunctional HUB with PDB, BEC 5V/2A & 12V/500mA, Current sensor 140A, STOSD8. It is specially made for the mini FPV Quad. The BEC 12V is linear regulator, no LC Filter needed. Built-in STOSD8 can support Plug & Play, no complicated settings needed.

### Functions

#### General

- Input voltage range (3S-5S operation): 8 - 21VDC
- PDB: 4x30A (Max.4x35A)
- Regulated 5V and 12V outputs
- Current Sensor 140A
- Built-in STOSD8
- Physical:
  - 2oz copper, 4-layers & 1.6mm PCB.
  - 1x Battery input, 4x ESC outputs. 2x BEC 5V outputs, 2x BEC 12V outputs.
  - Camera signal & Gnd pads, Video Transmitter Signal & Gnd pads
  - 1x Serial port (RX, TX, G)
  - Dimensions: 51x36x4mm, Weight: 9g
  - Mounting holes 30.5mm square spacing, Φ3mm

#### PDB (ESC outputs)

- Continuous current: 30A per output
- Peak current (10 seconds/minute): 35A per output

#### BEC 5V outputs

- Designed for RC Receivers, Flight controllers, OSD, and Servos.
- DC/DC synchronous buck regulator.
- Voltage: 5.0 +/- 0.1VDC
- Continuous current: 2 Amps (Max.2.5A 10s/minute)
- Output Ripple: 40mV (VIN=16V, VOUT=5V@2A load)
- Short-circuit tolerant (5 seconds/minute)

#### BEC 12V outputs

- Linear regulator, very low noise. LC Filter is needless.
- Designed for Video TX or FPV camera.
- Voltage: 12.0 +/- 0.3VDC (4~5S operation)
- Continuous current: 500mA@16V IN, 400mA@20V IN
- Short-circuit tolerant (2 seconds/minute)
- If the battery is 3S LiPo, Output voltage=3S LiPo voltage - 1V

#### Current Sensor

- 140A
- If current >140A. STOSD display 140A

#### STOSD8

- **Running indicator**  
Blue LED blinks: STOSD is initializing  
Blue LED light: STOSD is working.
- **Autodetect PAL/NTSC**  
Auto sense PAL / NTSC cam at OSD startup. Default is NTSC without Cam signal
- **Dynamic on screen info**  
Current < 2A & keep 5 seconds  

MatekSYS		
16.28V	14.56V	280
1.5A	138.9A	01:20

MatekSYS	
14.60V	1050
56.9A	02:35
- **Min.Volt & Max.Amp recorder**
- **Automatic flight timer**  
Current > 2A, Time in. Current < 2A, Time out..
- **Auto battery cells detection**  
If the Input voltage is in the range of following, The HUBOSD will detect the cell numbers automatically.  
11.1~13.05V: 3cells LiPo, 14.8~17.4V: 4cells LiPo, 18.5~21V: 5cells LiPo  
If the input voltage is out of the range. The voltage value will blink on screen. Pls check if the battery total voltage is below 3.7V\*cells
- **Low voltage alarm** (Value blinks): Default 3.6V\* cells
- **Exceeding mAh alarm** (Value blinks): Default 1000mAh
- **Onscreen Pilot ID**  
Default is disable. you can type some words & enable it in GUI
- **Firmware upgradable**
- Voltage precision: +/- 0.4%, Voltage resolution: 0.01V  
Current precision: +/- 1.5%, Current resolution: 0.1A

### Layout

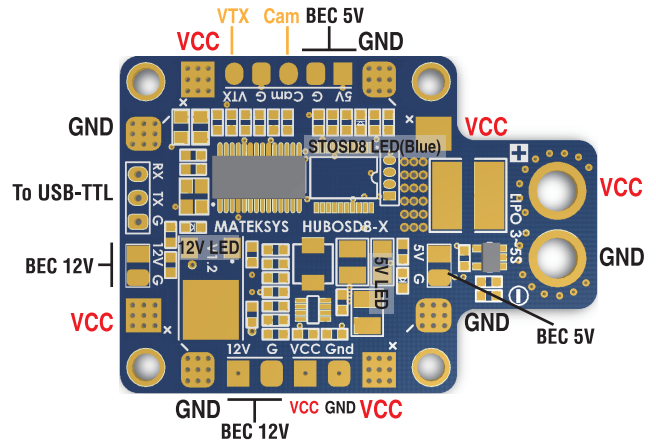

Serial port(RX TX G), Use for Setting & Firmware upgrading only.  
VCC = Battery Voltage

### Connections

