

Flyduino KISS Flight Controller Manual v1.06

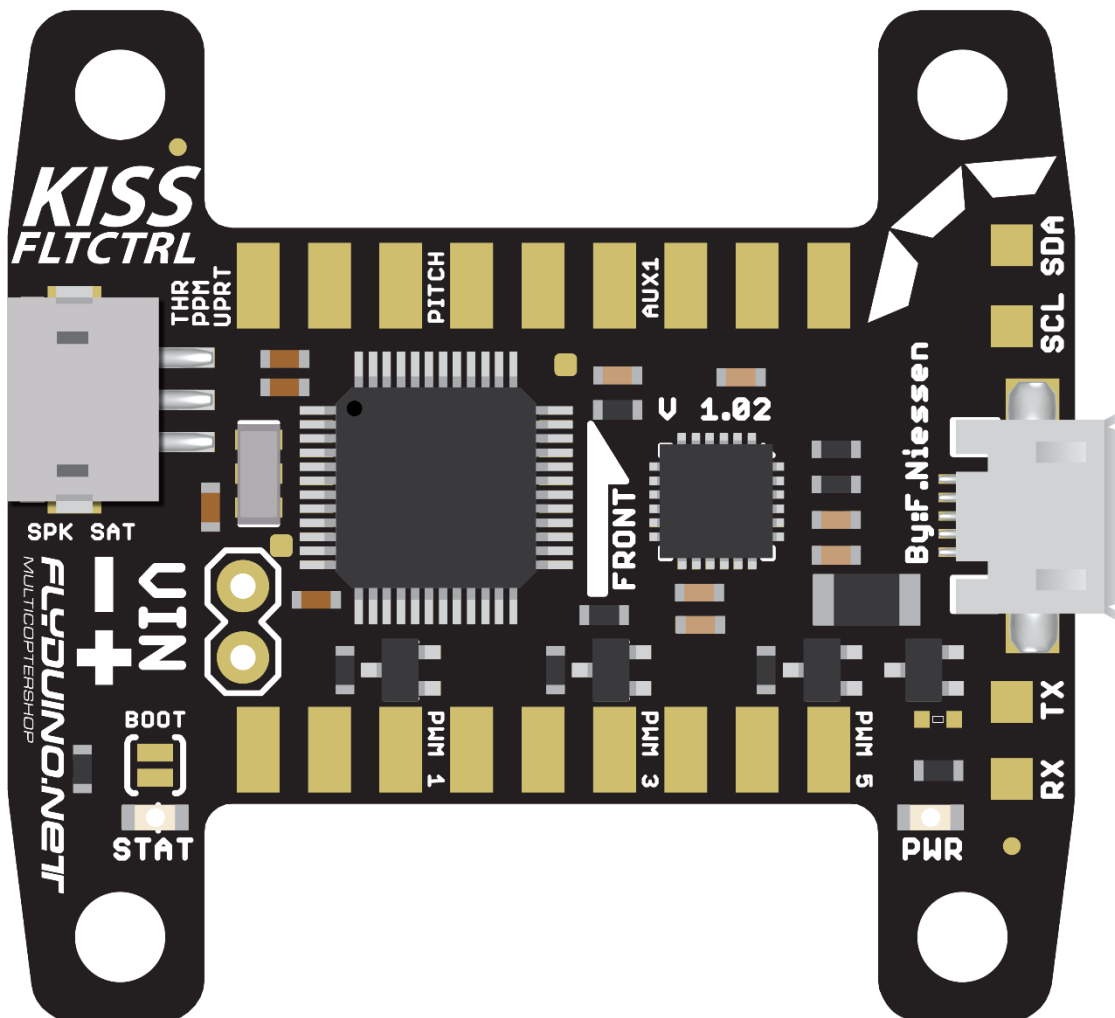

Image: Upper / Top Side

As we felt the need for a modern more simplified 32bit Flight controller, we made the KISS FC, which includes a complete own Flight Control Firmware development who get rid of some old ballast, this took some time, but the result is very pleasing.

The Idea was to simplify some things and due to intensive long term tests of some pretty good Pilots we were able to optimize the code to a point where you hopefully get your quad in the air quite quick.

Normally you just need to choose your Airframe in the GUI and are able to fly (at least with KISS ESC), otherwise you can download presets of well known pilots for given configurations and of course you can tweak the PID yourself through the GUI.

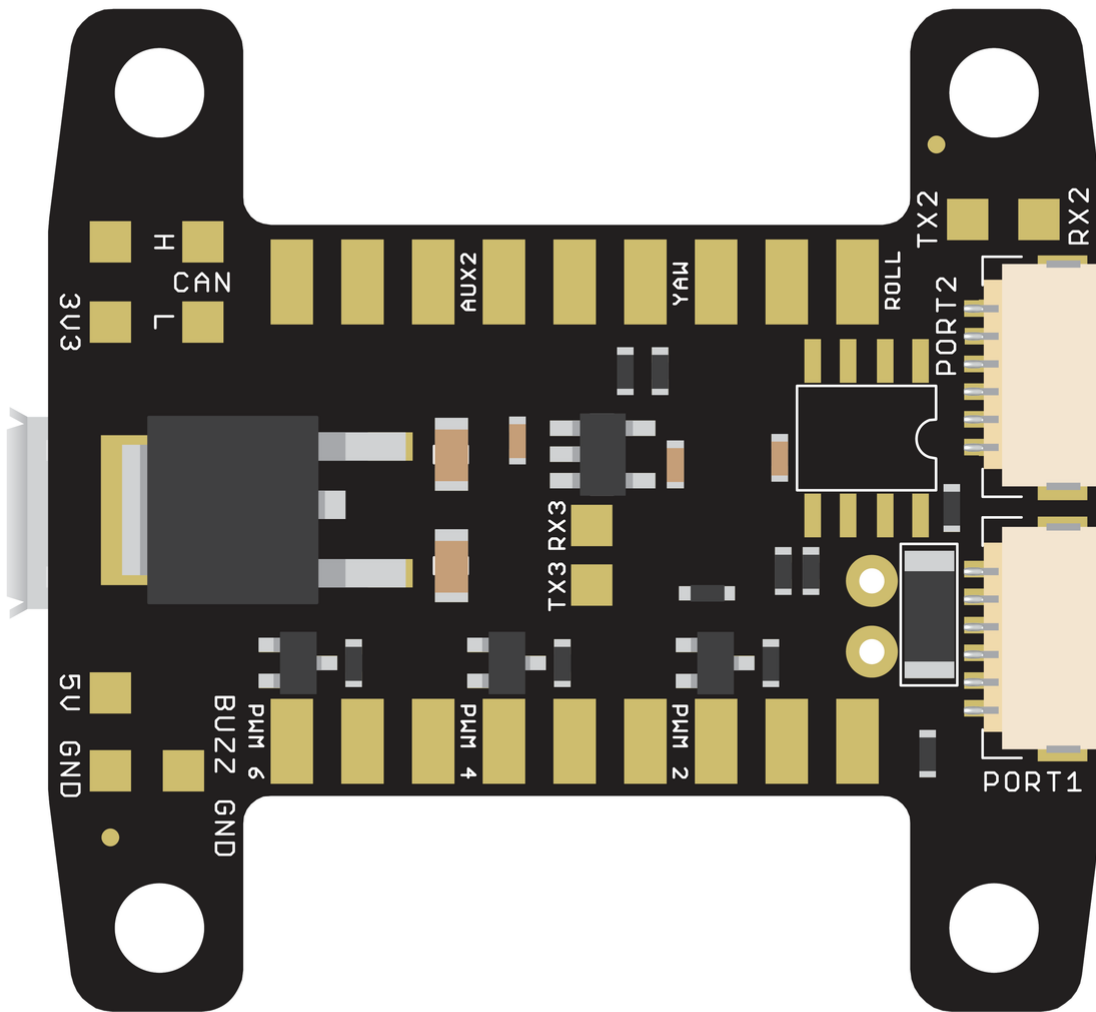

Image: Lower / Bottom Side

The software setup side is reduced as far we can, many things are already taken into account for you, if you have some solid soldering skills you should be able to build your quad pretty quick.

A new feature is also the build telemetry, in combination with our 32bit ESC line its possible to show the live telemetry data via OSD on your FPV live feed or in the KISS FC GUI

This way you get useful informations like the Voltage of your battery, current consumption, ESC temperature and motor RPM.

Other FC firmwares (eg. Cleanflight) can be ported for the use with the KISS FC.

NOTE: Always keep the FC level and firm for at least 5 seconds after you powered it!

If you move it, the gyro calibration might fail, indicated by the blue LED staying solid and the GUI showing the MCU idle of ~55%. **On startup the green LED should be lit and the blue one should be flashing for several seconds, then go solid for a second and if the calibration is complete go off.**

Table of Content

Flyduino KISS Flight Controller Manual v1.06	1
Supported Copter frames	4
Supported Receivers	5
Connections	6
GUI (Graphical User Interface).....	9
Advanced Configuration	10
Installation & Setup.....	11
Sharing PIDs	11
PID Presets	12
PID and Rate Tuning.....	13
Low Pass Filters	14
AUX Channel Settings.....	15
ESCs Throttle Calibration	15
Throttle Calibration for KISS ESCs in 3D Mode	16
Flashing the Firmware.....	16
Air Mode	18
Telemetry / OSD.....	19
External Modules	20
Telemetry for specific RC Transmitters/Receivers.....	21
FrSky Telemetry via S-Port	21
JETI DX	22
Graupner HOTT Telemetry.....	23
MultiPlex	24
Bluetooth Connection	27

Supported Copter frames

- Tri, Y4, Y6
- Quad +/-
- Hexa +/-

The screenshot shows the configuration interface for a KISS FC. At the top, there's a status bar with 'COM45', 'Disconnect', and navigation tabs for 'Welcome', 'Configuration', and 'Data Output'. The main interface is divided into several sections:

- UAV Type:** A dropdown menu is set to 'Quad X'. Below it is a diagram of a quadcopter with four motors labeled PWM1, PWM2, PWM3, and PWM4.
- Receiver:** A dropdown menu is set to 'PPM:Pitch,Roll,Thr.,Yaw'. Below it is a slider for 'FS. levelmode Sec.' set to 5.
- PID & Rates:** A table for configuring PID values and rates for Roll, Pitch, Yaw, and TPA. Presets are set to 'custom'.

	P	I	D	RC Rate	Rate	RC Curve
Roll	3	0.035	10	0.7	0.7	0.4
Pitch	3	0.035	10	0.7	0.7	0.4
Yaw	8	0.05	0	0.7	0.7	0.4
TPA	0.4	0.2	0.4			

 Below the table is a 'Level' section with values 4, 0.04, 10, and 50.
- General Settings:** A list of settings including Min. Throttle (1070), Max. Throttle (2000), Min. Command (1075), Mid. Command (1500), Tri Yaw Mid. (1500), Tri Yaw Invert (unchecked), OneShot 125 (checked), OneShot 42 (unchecked), 3D Mode (unchecked), and FC Rotated by 180° (unchecked).
- Aux Channel Settings:** Four AUX channels are all set to 'No Action'.
- Filter:** LPF FRQ is set to 'High'.

At the bottom, there's a 'show advanced configuration' link and a green 'Save Settings' button.

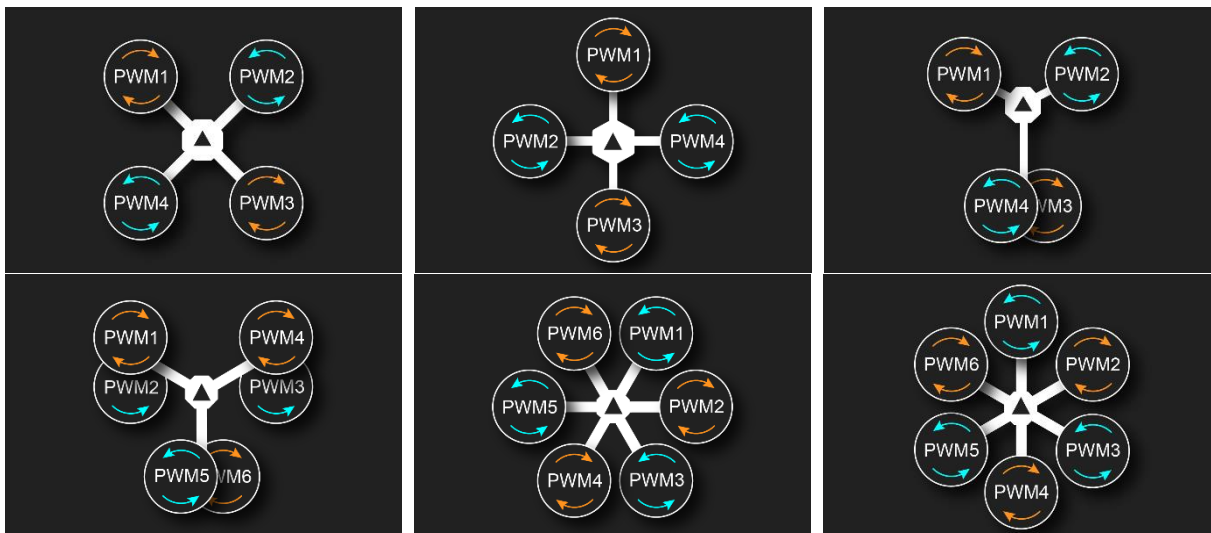

Supported Receivers

Receiver	PWM	PPM	Digital	Telemetry	Protocols
Spektrum	Yes	Yes	Yes (Spektrum Sat)		DSM2 + DSMX
Futaba	Yes	Yes	Yes		SBUS
FrSky	Yes	Yes	Yes	Yes (X-Series RX)	SBUS + S-Port
Jeti	Yes	Yes	Yes	Yes	Jeti DX + EX Bus
Graupner	Yes	Yes	Yes	Yes	HOTT
Hitec / Traditional	Yes	Yes			
Multiplex	Yes		Yes	partially	SRXL + MSB

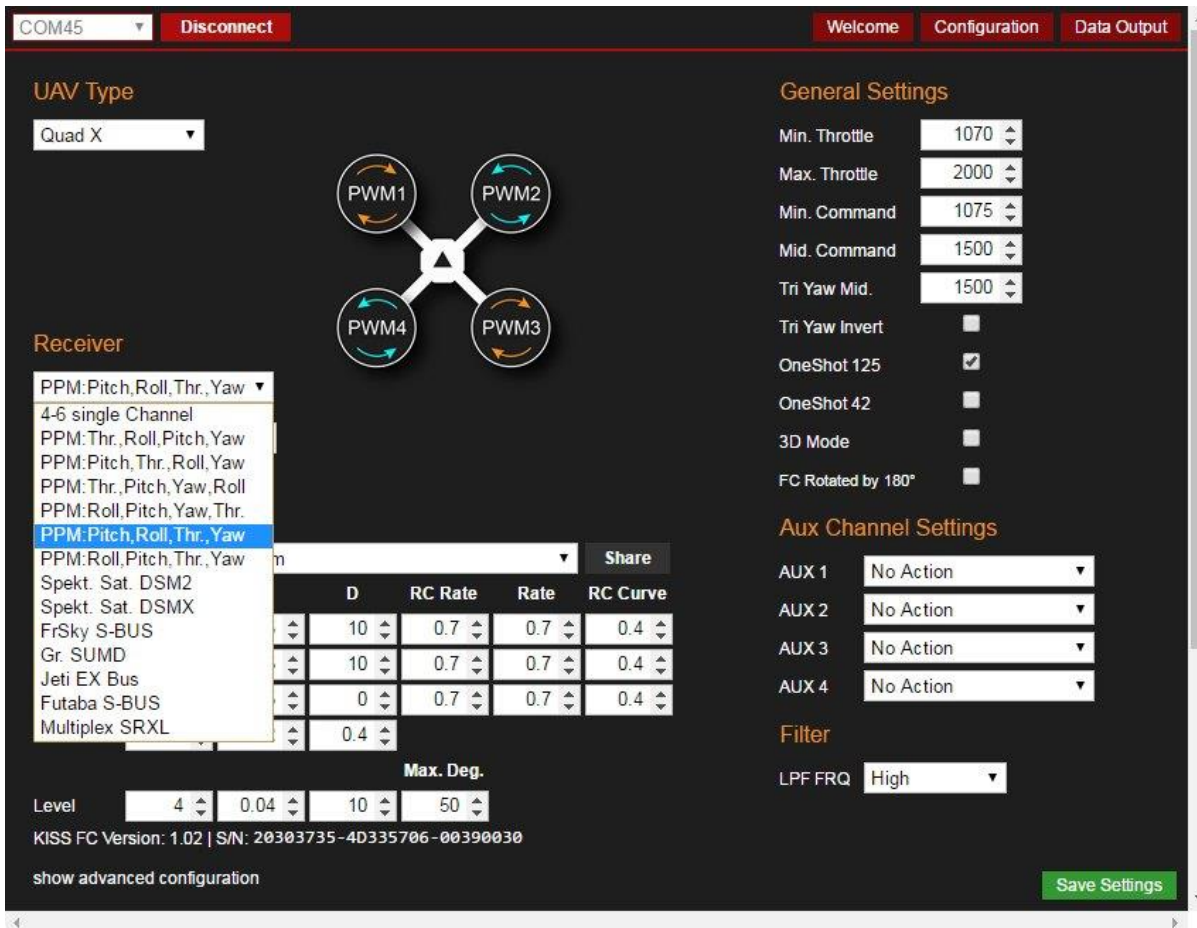

The screenshot shows the configuration interface for the KISS FC. At the top, there are tabs for 'Welcome', 'Configuration', and 'Data Output'. The 'Configuration' tab is active, showing a 'UAV Type' dropdown set to 'Quad X' and a 'Receiver' dropdown menu. The receiver menu is open, showing options like 'PPM:Pitch,Roll,Thr.,Yaw' and 'Spekt. Sat. DSM2'. Below the menu is a table with columns for 'D', 'RC Rate', 'Rate', and 'RC Curve'. To the right, there are 'General Settings' for throttle and command values, and 'Aux Channel Settings' for AUX 1-4. At the bottom, there are 'Level' settings and a 'Save Settings' button.

There are 8 Receiver inputs and channels: 4 for the sticks and 4 AUX channels 1-4

Other Specs & Features

MCU: STM32F303CCT6

IMO: MPU6050

Weight: 4.6g

Mounting Holes: 3x3cm pattern with 3.2mm holes (compatible with most frame types)

Voltage: 2-6S (direct, max. 5s recommended)

The needed USB driver usually will be installed when you connect the FC for the first time. It may take several minutes before you can use the FC and connect it to the GUI.

Connections

You can find the connection diagram / pinout on the Welcome page of the GUI. **TRX** = Telemetry In

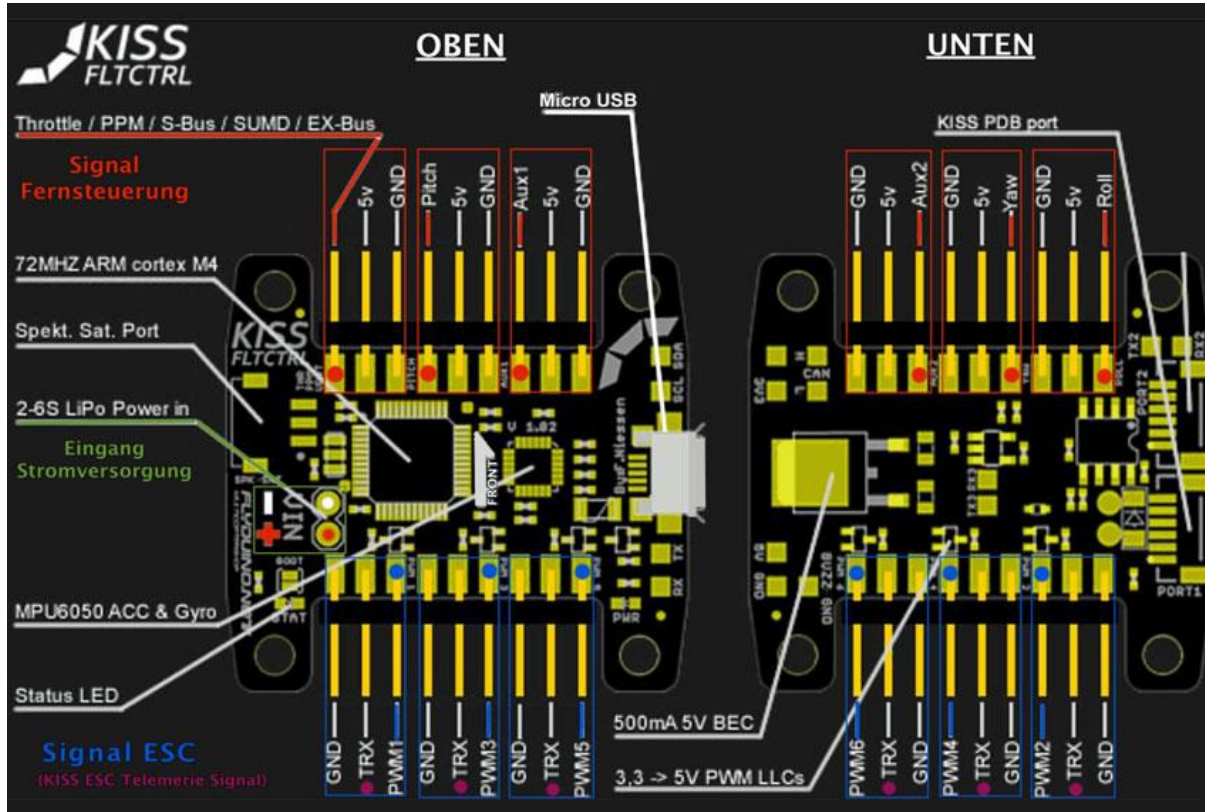

There are 6 PWM outputs for 2-6 Motors or Servos

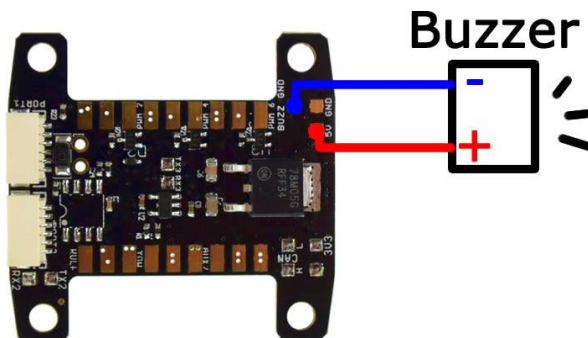
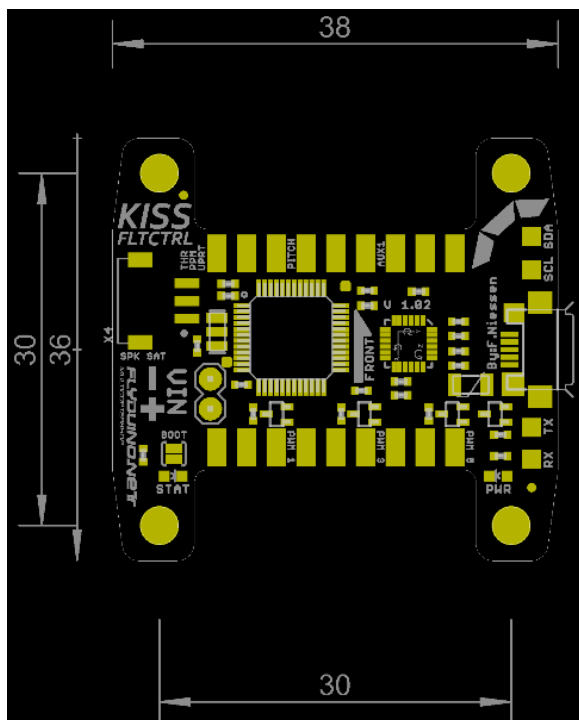

PWM = ESC Signal Lines | TRX = Telemetry | GND = Ground
 Always connect the Ground and Signal, TRX goes to TLM on the KISS ESC24A
 PWM 1 - 4 are used for the ESCs on a Quad, PWM 5 + 6 can be used for other puposes

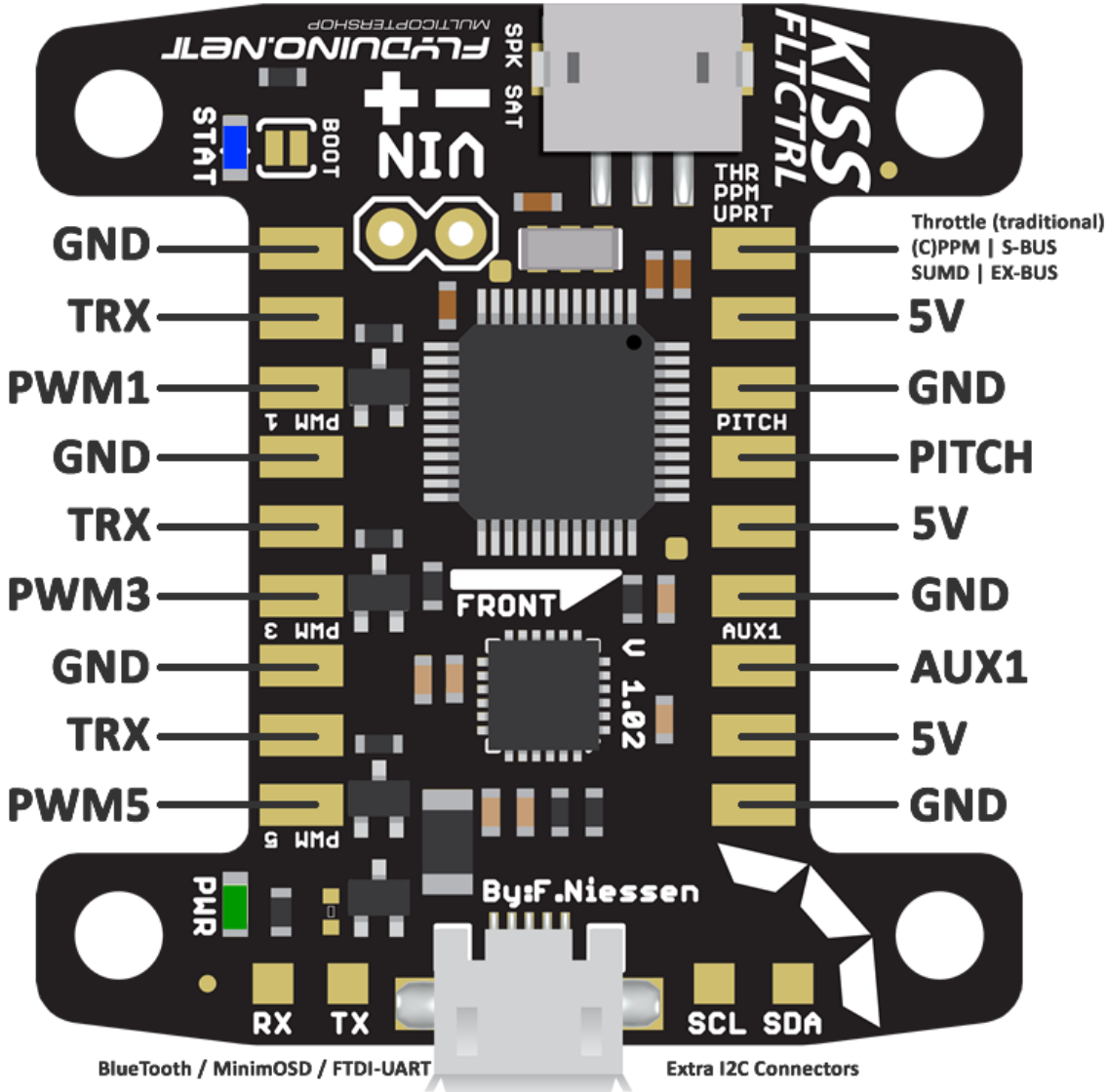

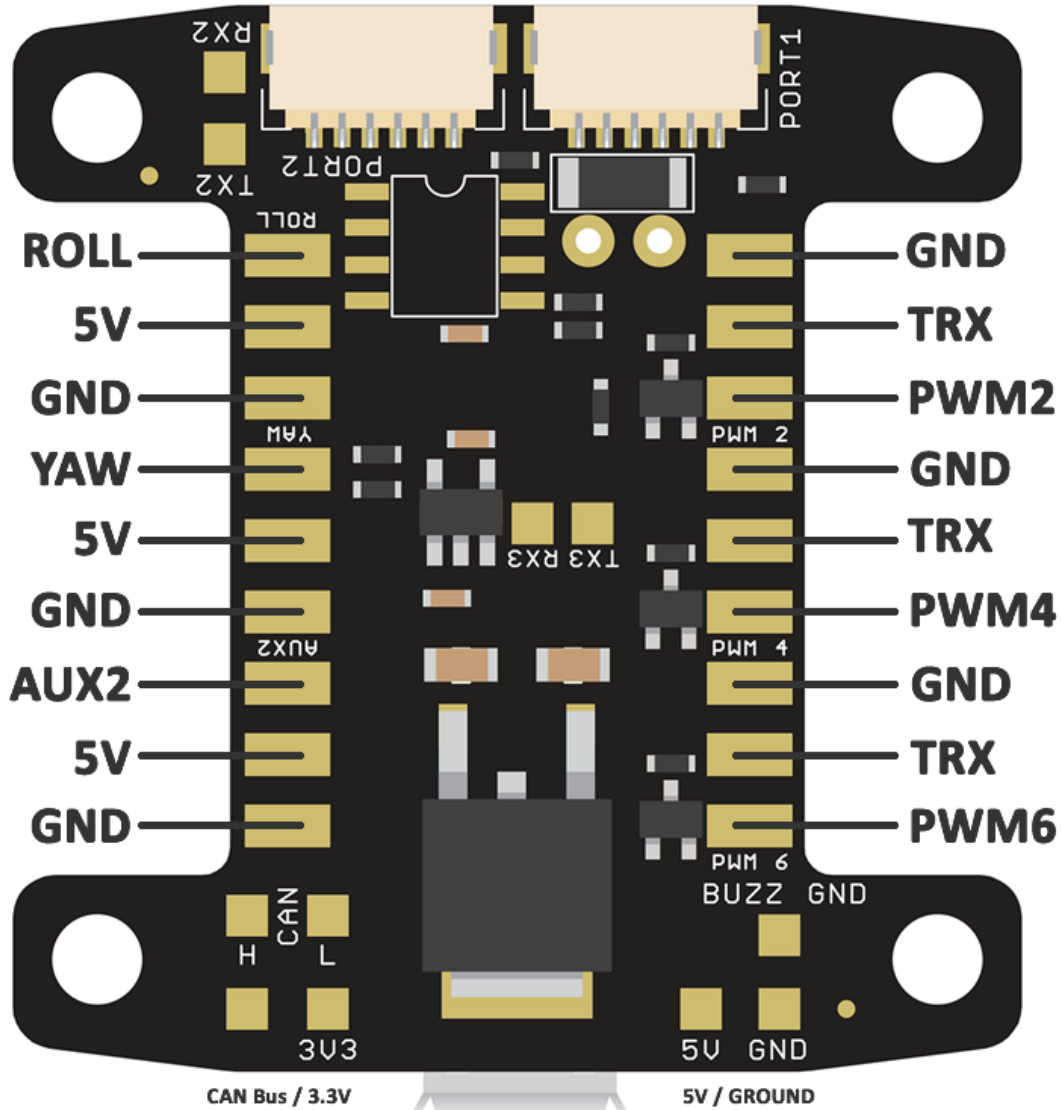

GUI (Graphical User Interface)

The GUI consists of 3 pages: The „Welcome“ page with all connections, the „Configuration“ page for the settings and „Data Output“ for Sensorgraphs.

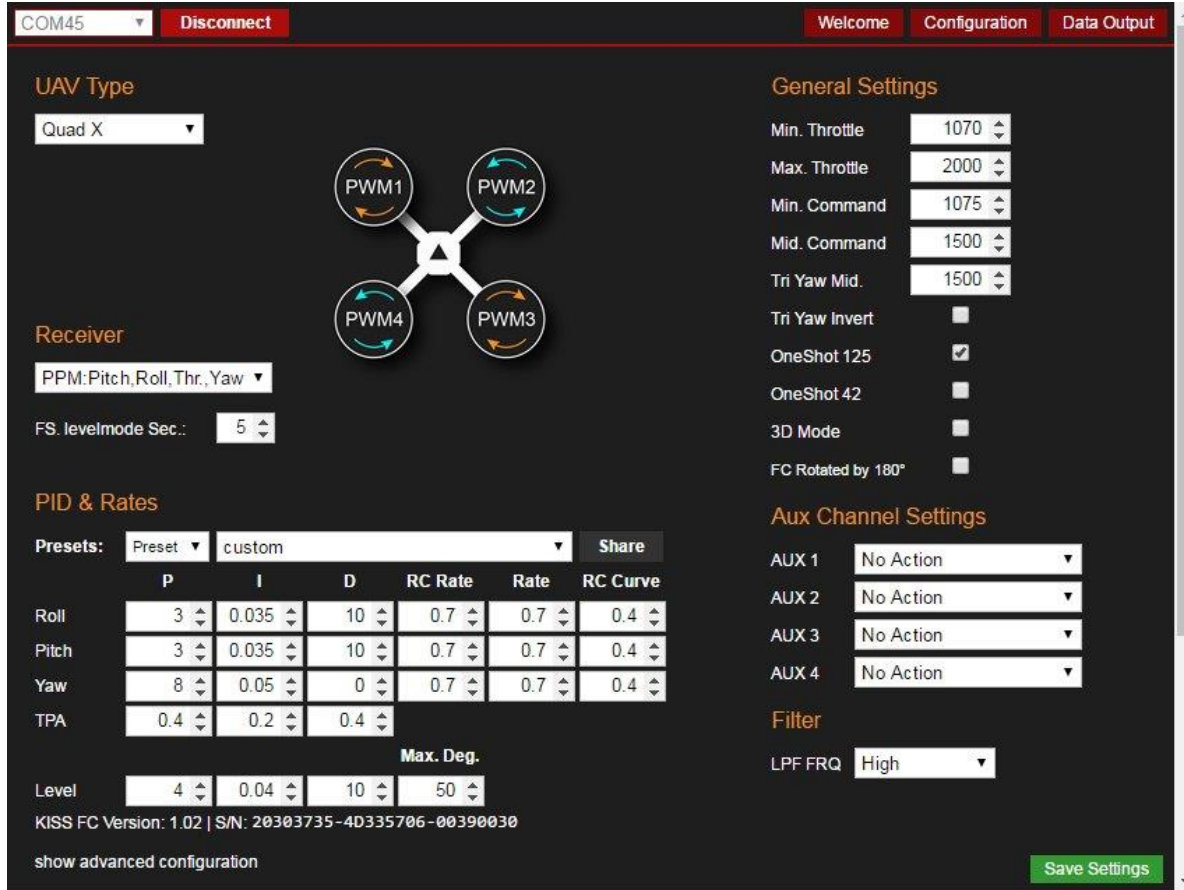

The screenshot shows the 'Configuration' page of the KISS GUI. At the top, there are navigation tabs for 'Welcome', 'Configuration', and 'Data Output'. The main interface is divided into several sections:

- UAV Type:** A dropdown menu set to 'Quad X'.
- Receiver:** A dropdown menu set to 'PPM:Pitch,Roll,Thr.,Yaw' and a 'FS. levelmode Sec.' field set to '5'.
- PID & Rates:** A table for configuring PID parameters and rates.

	P	I	D	RC Rate	Rate	RC Curve
Roll	3	0.035	10	0.7	0.7	0.4
Pitch	3	0.035	10	0.7	0.7	0.4
Yaw	8	0.05	0	0.7	0.7	0.4
TPA	0.4	0.2	0.4			
- General Settings:** A list of settings including 'Min. Throttle' (1070), 'Max. Throttle' (2000), 'Min. Command' (1075), 'Mid. Command' (1500), 'Tri Yaw Mid.' (1500), 'Tri Yaw Invert' (unchecked), 'OneShot 125' (checked), 'OneShot 42' (unchecked), '3D Mode' (unchecked), and 'FC Rotated by 180°' (unchecked).
- Aux Channel Settings:** Four dropdown menus for AUX 1, 2, 3, and 4, all set to 'No Action'.
- Filter:** A dropdown menu for 'LPF FRQ' set to 'High'.

At the bottom, there is a 'show advanced configuration' link and a green 'Save Settings' button.

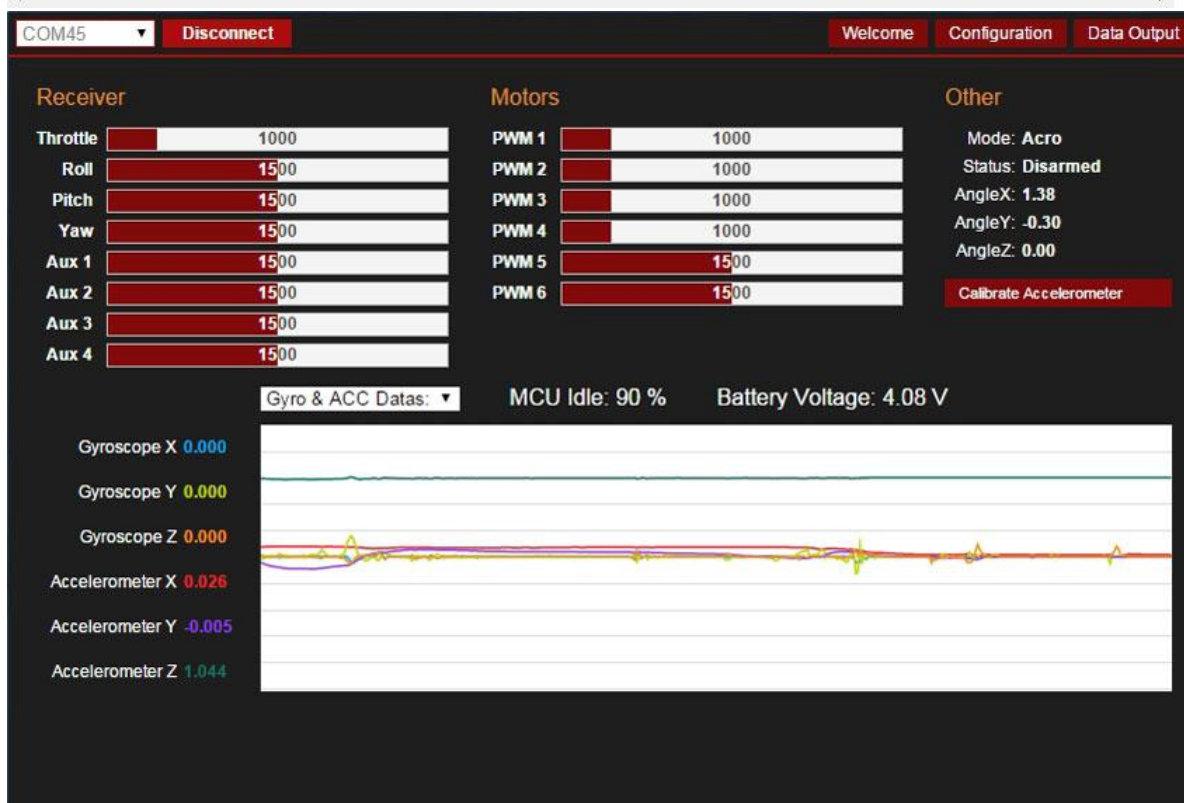

The screenshot shows the 'Data Output' page of the KISS GUI. At the top, there are navigation tabs for 'Welcome', 'Configuration', and 'Data Output'. The main interface is divided into several sections:

- Receiver:** A list of receiver channels with their current values: Throttle (1000), Roll (1500), Pitch (1500), Yaw (1500), Aux 1 (1500), Aux 2 (1500), Aux 3 (1500), and Aux 4 (1500).
- Motors:** A list of motor channels with their current values: PWM 1 (1000), PWM 2 (1000), PWM 3 (1000), PWM 4 (1000), PWM 5 (1500), and PWM 6 (1500).
- Other:** A list of other parameters: Mode: Acro, Status: Disarmed, AngleX: 1.38, AngleY: -0.30, AngleZ: 0.00, and a 'Calibrate Accelerometer' button.
- System Status:** 'Gyro & ACC Datas' dropdown, 'MCU Idle: 90 %', and 'Battery Voltage: 4.08 V'.
- Sensor Graphs:** A graph showing Gyroscope X (0.000), Gyroscope Y (0.000), Gyroscope Z (0.000), Accelerometer X (0.026), Accelerometer Y (-0.005), and Accelerometer Z (1.044) over time.

Advanced Configuration

If you connect a KISS FC with version 1.02x on it you will get a small extra button that can be seen, when enlarging the GUI window in configuration tab.

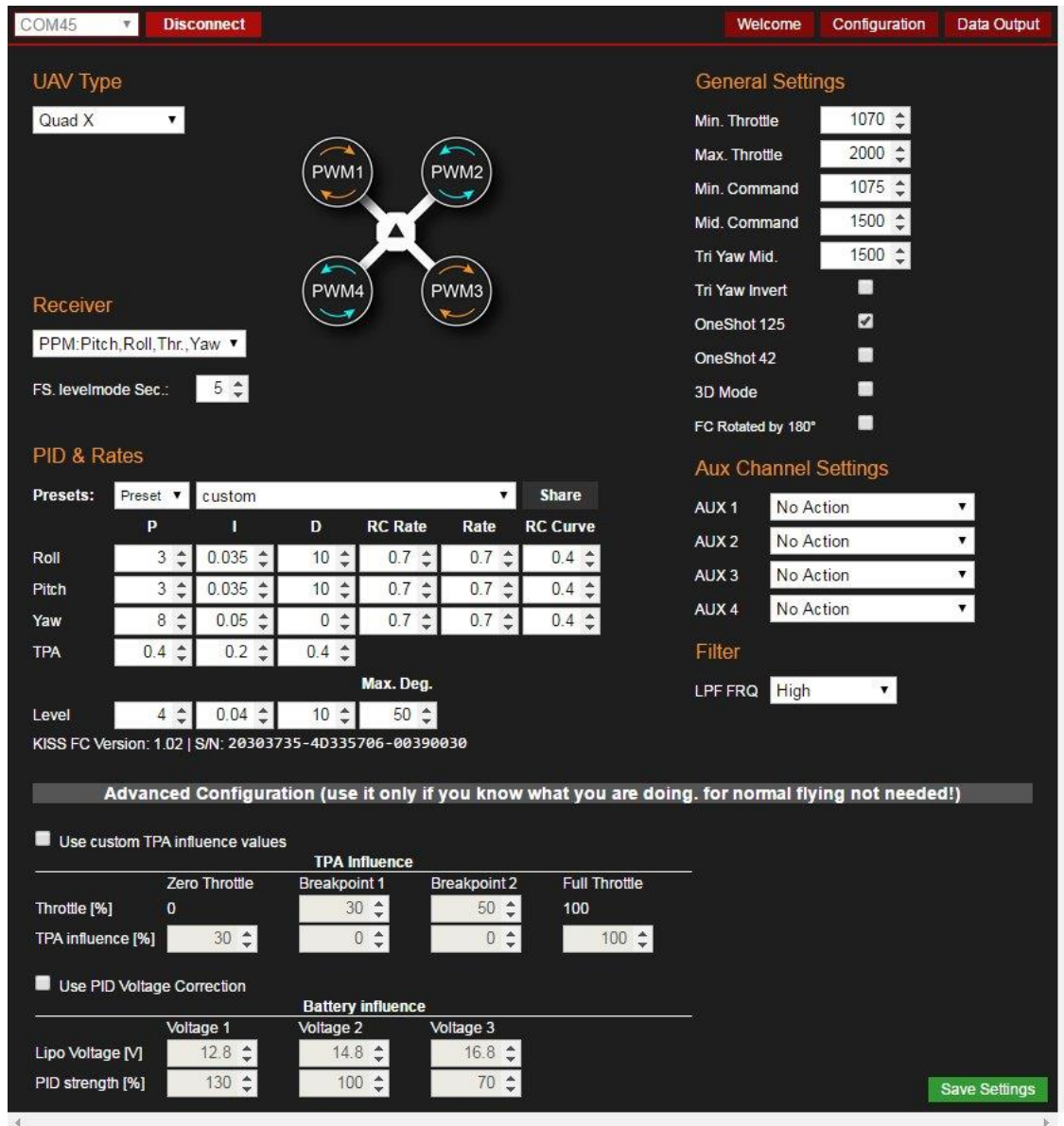

The screenshot shows the configuration interface for a KISS FC. At the top, there are tabs for 'Welcome', 'Configuration', and 'Data Output'. The 'Configuration' tab is active, showing various settings sections:

- UAV Type:** Set to 'Quad X'.
- Receiver:** Set to 'PPM:Pitch,Roll,Thr.,Yaw'.
- PID & Rates:** A table for configuring PID gains and rates for Roll, Pitch, Yaw, and TPA. Preset is set to 'custom'.
- General Settings:** Includes Min. Throttle (1070), Max. Throttle (2000), Min. Command (1075), Mid. Command (1500), Tri Yaw Mid. (1500), Tri Yaw Invert (unchecked), OneShot 125 (checked), OneShot 42 (unchecked), 3D Mode (unchecked), and FC Rotated by 180° (unchecked).
- Aux Channel Settings:** AUX 1, 2, 3, and 4 are all set to 'No Action'.
- Filter:** LPF FRQ is set to 'High'.

At the bottom of the configuration window, there is a section for 'Advanced Configuration (use it only if you know what you are doing. for normal flying not needed!)'. This section includes:

- Use custom TPA influence values:** A table for 'TPA influence' with columns for Zero Throttle, Breakpoint 1, Breakpoint 2, and Full Throttle. Values are: Zero Throttle (0), Breakpoint 1 (30), Breakpoint 2 (50), Full Throttle (100). TPA influence [%] is set to 30.
- Use PID Voltage Correction:** A table for 'Battery influence' with columns for Voltage 1, Voltage 2, and Voltage 3. Values are: Voltage 1 (12.8), Voltage 2 (14.8), Voltage 3 (16.8). PID strength [%] is set to 130.

A 'Save Settings' button is located at the bottom right of the configuration window.

You can setup TPA influence and Battery influence

TPA influence

here you can configure the influence of the TPA values in relation to the throttle.

Battery influence

its ment to decouple the PID values from the lipos voltage. (normaly PID's feel stronger with higher voltage)

Note: If you are already using a previous version of the Chrome App, please uninstall it first and load the actual version (recently v1.05) from here:

<https://chrome.google.com/webstore/detail/kissfc/hecmfiemalajlglaajmnpjhjmnkinpm>

Installation & Setup

Note: the USB port might get warm during operation. This is due to the used voltage regulator which needs to be able to handle 6s. This behavior should not be a problem at all.

Just plug in the FC via Micro USB connection to your PC. Drivers should be installed automatically on WIN7-10. After the installation is complete, unplug the FC from the USB, plug it in again and hold the FC firm and level for at least 5 seconds!

Arming can be done via switch on the Transmitter or via stick input: Throttle down, Yaw right will arm, Throttle down, Yaw left will disarm.

The green LED will be lit constantly while the blue LED will blink, indicating the Gyro calibration. It will be solid afterwards and go off when the calibration is completed and the FC is ready to go.

Then start the Chrome GUI and select the COM port for the connection. If no port is shown, the driver installation might have failed.

Important! For safety reasons the PIDs will only be saved when NO LIPO is attached!

Sharing PIDs

The default PIDs should be good enough for a start. However if you want to tune the FC to the max and squeeze the last bit of performance out of it, you will need to fine tune the settings.

A great feature of the GUI is the "Share" button, where you can submit your PIDs with other users. This can be a good starting point for beginners with similar setups. Please don't abuse that function!

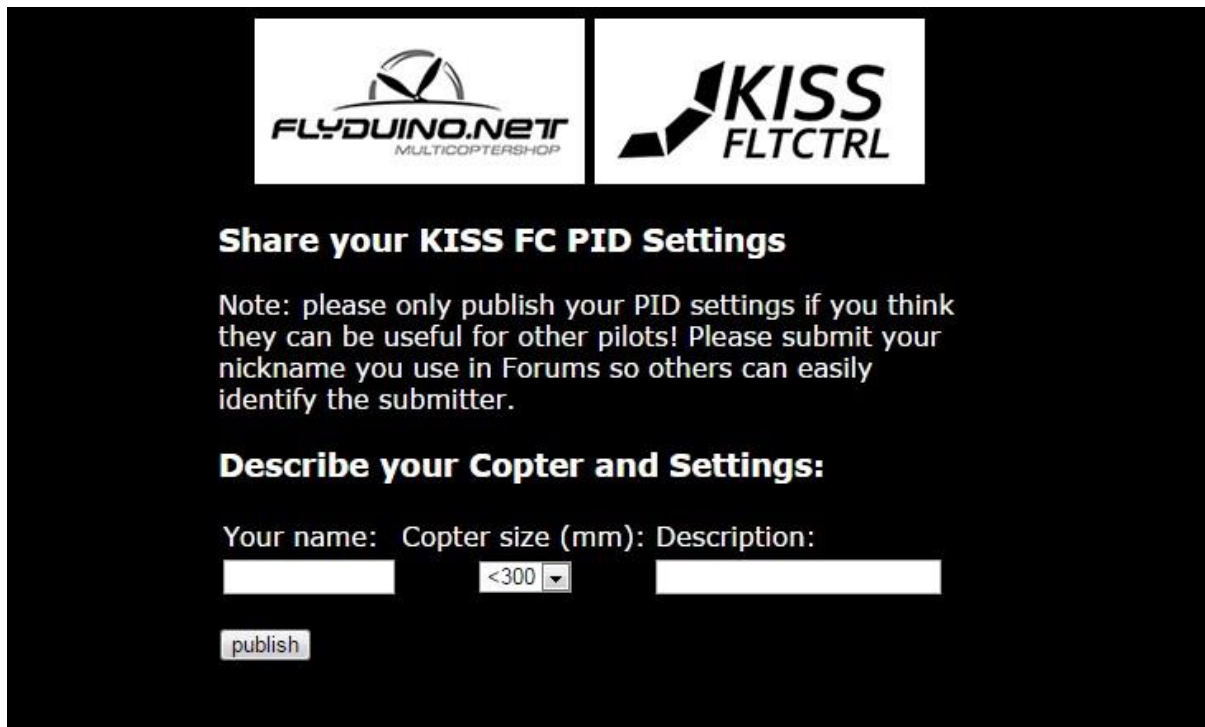

Please submit your nickname used in forums to make it easier to identify the submitter for others. We will refine this function in the future to assure only flyable PIDs make it into the list.

PID Presets

COM45
Disconnect
Welcome
Configuration
Data Output

UAV Type

Quad X



Receiver

PPM:Pitch, Roll, Thr., Yaw

FS. levelmode Sec.: 5

PID & Rates

Preset	Share	RC Curve
custom		0.4
custom		0.4
default		0.4
WT MiniCP		0.4
WT CP 18-25cm		0.4
WT FQuad		0.4
QR 270		0.4
QR 400		0.4
ZMR 250		0.4

Level: 4, 0.04, 10, 50

KISS FC Version: 1.02 | S/N: 20303735-4D335706-00390030

[show advanced configuration](#)

General Settings

Min. Throttle: 1070

Max. Throttle: 2000

Min. Command: 1075

Mid. Command: 1500

Tri Yaw Mid.: 1500

Tri Yaw Invert:

OneShot 125:

OneShot 42:

3D Mode:

FC Rotated by 180°:

Aux Channel Settings

AUX 1: No Action

AUX 2: No Action

AUX 3: No Action

AUX 4: No Action

Filter

LPF FRQ: High

Save Settings

Adjust your settings with care! Only use small steps to increase or decrease the numbers and only one at a time. To make a start easier the GUI offers pre-defined PIDs for several setups tested by skilled pilots. More presets will be available once user share theirs.

PID and Rate Tuning

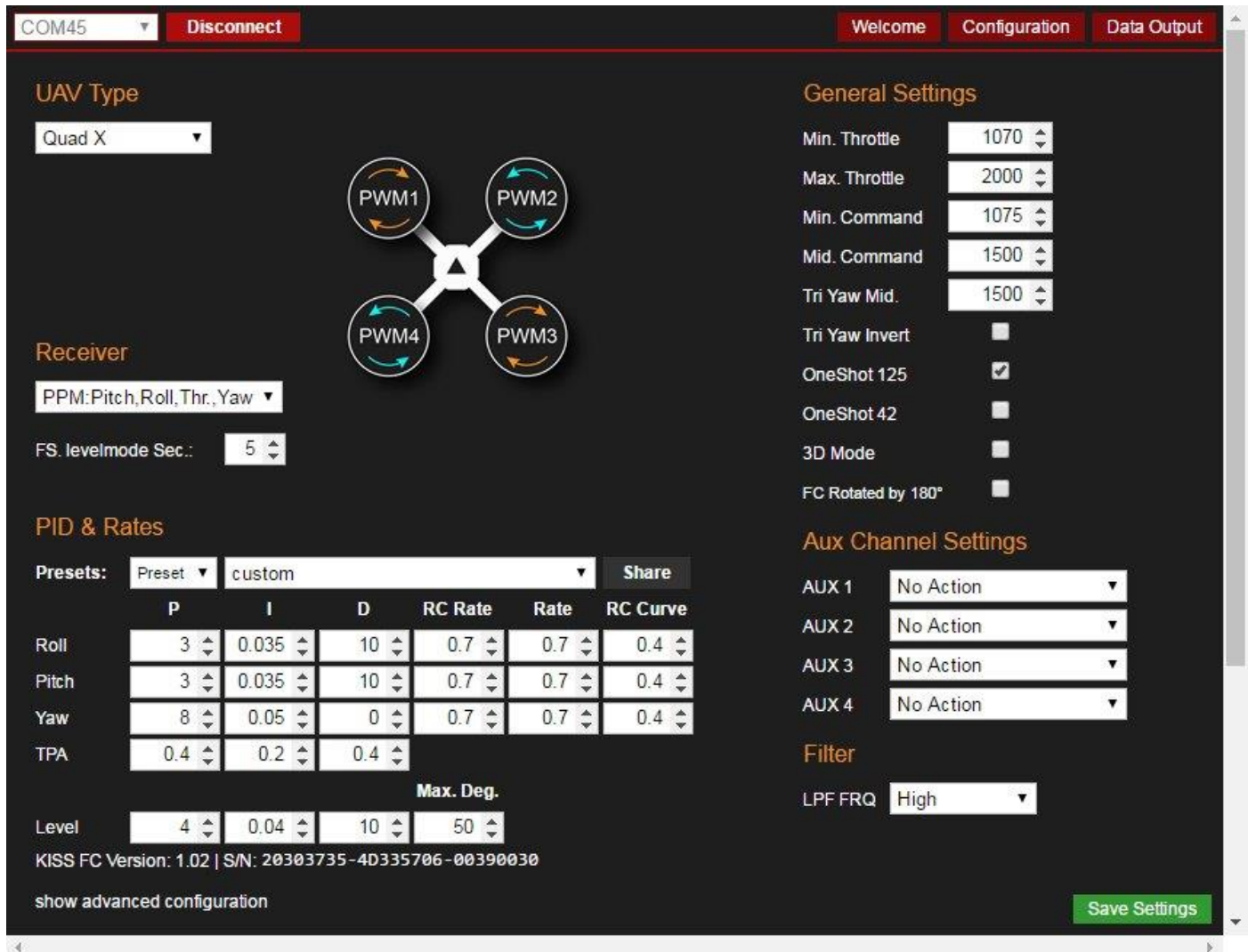

The screenshot shows the KISS FC configuration interface. At the top, there are tabs for 'COM45', 'Disconnect', 'Welcome', 'Configuration', and 'Data Output'. The 'Configuration' tab is active.

UAV Type: Quad X

Receiver: PPM:Pitch, Roll, Thr., Yaw

FS. levelmode Sec.: 5

PID & Rates:

	P	I	D	RC Rate	Rate	RC Curve
Roll	3	0.035	10	0.7	0.7	0.4
Pitch	3	0.035	10	0.7	0.7	0.4
Yaw	8	0.05	0	0.7	0.7	0.4
TPA	0.4	0.2	0.4			

Level: 4, 0.04, 10, 50 (Max. Deg.)

KISS FC Version: 1.02 | S/N: 20303735-4D335706-00390030

General Settings:

- Min. Throttle: 1070
- Max. Throttle: 2000
- Min. Command: 1075
- Mid. Command: 1500
- Tri Yaw Mid.: 1500
- Tri Yaw Invert:
- OneShot 125:
- OneShot 42:
- 3D Mode:
- FC Rotated by 180°:

Aux Channel Settings:

- AUX 1: No Action
- AUX 2: No Action
- AUX 3: No Action
- AUX 4: No Action

Filter: LPF FRQ: High

Buttons: 'show advanced configuration' and 'Save Settings'.

Rate decreases the gyro influence depending on the stick max outputs. E.g. with roll stick at center you will always have 100% gyro influence with rate on 0.00 it will still be 100% with full roll left. But with 0.50 rate it will be 50% gyro influence at full roll left or right.

Rate also gives an Expo like feeling. So to keep the same Expo strength you may lower one if you increase the other.

RC Rate increases the strength of the RC channel signals into the PID controller. so e.g. if you have 0-1000 at RC rate 1.0, it will be 0-2000 with RC rate 2.0

RC Curve is like the Expo on your TX. It lowers the inputs around the middle. You can adjust the RC Curve with 0.01 steps.

Online Tool to calculate the Rate values: <http://ultraesc.de/KISSFC/rates.html>

Low Pass Filters

COM45
Disconnect
Welcome
Configuration
Data Output

UAV Type

Quad X



Receiver

PPM:Pitch, Roll, Thr., Yaw

FS. levelmode Sec.: 5

PID & Rates

Presets: Preset | custom | Share

	P	I	D	RC Rate	Rate	RC Curve
Roll	3	0.035	10	0.7	0.7	0.4
Pitch	3	0.035	10	0.7	0.7	0.4
Yaw	8	0.05	0	0.7	0.7	0.4
TPA	0.4	0.2	0.4			

Max. Deg.

Level	4	0.04	10	50
-------	---	------	----	----

KISS FC Version: 1.02 | S/N: 20303735-4D335706-00390030

show advanced configuration

General Settings

Min. Throttle: 1070

Max. Throttle: 2000

Min. Command: 1075

Mid. Command: 1500

Tri Yaw Mid.: 1500

Tri Yaw Invert:

OneShot 125:

OneShot 42:

3D Mode:

FC Rotated by 180°:

Aux Channel Settings

AUX 1: No Action

AUX 2: No Action

AUX 3: No Action

AUX 4: No Action

Filter

LPF FRQ: High

- High
- Off
- High
- Medium High
- Medium
- Medium Low
- Low
- Very Low

Save Settings

The GUI offers presets for low pass filters to get rid of possible oscillations. The lower you choose the frequency, the more filtering will occur. You can either turn filtering off completely or select one of the other presets to match your setup. "Very Low" offers the most filtering, "High" is the least affecting filter.

AUX Channel Settings

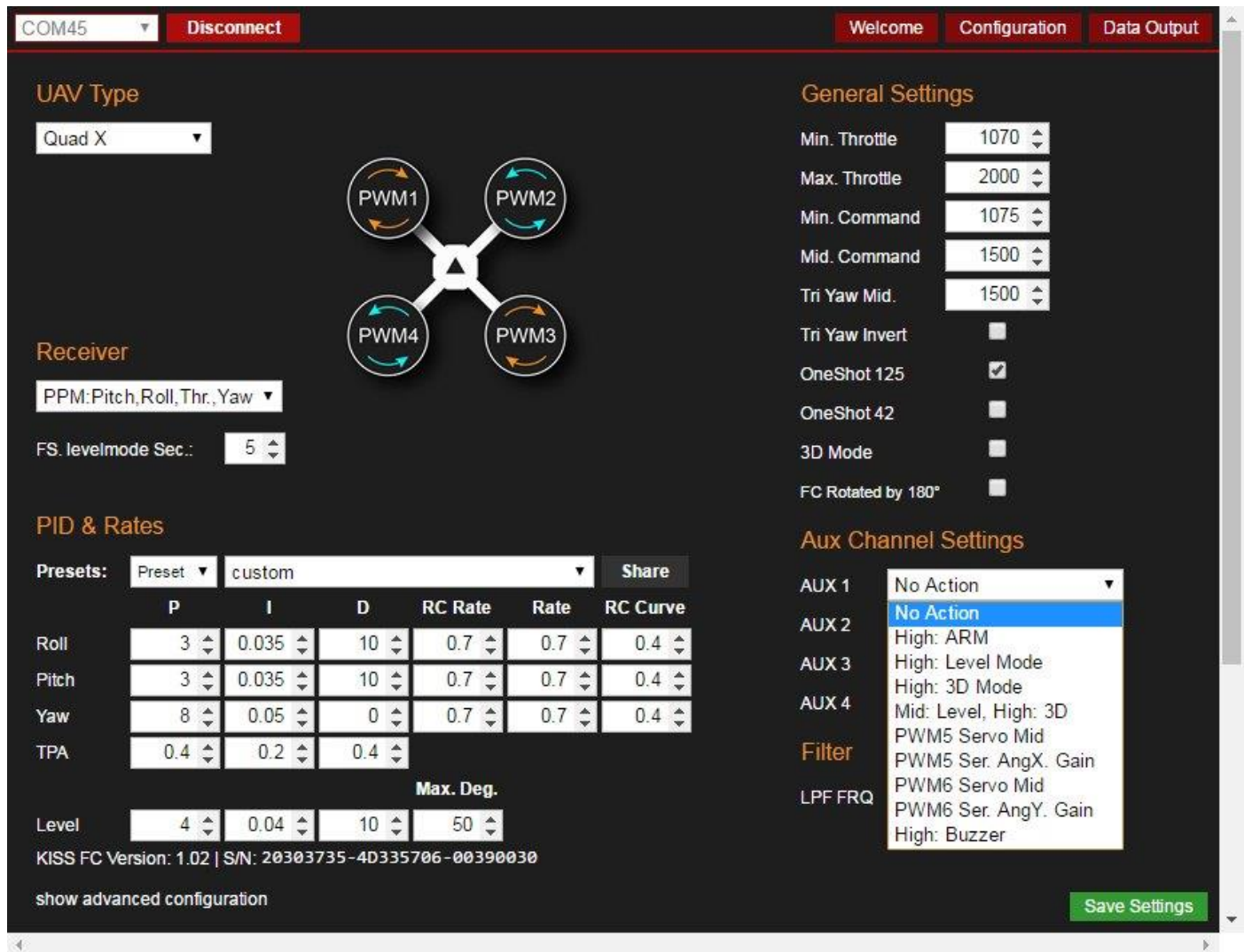

COM45 Disconnect Welcome Configuration Data Output

UAV Type
Quad X

Receiver
PPM: Pitch, Roll, Thr., Yaw
FS. levelmode Sec.: 5

PID & Rates

Presets: Preset custom Share

	P	I	D	RC Rate	Rate	RC Curve
Roll	3	0.035	10	0.7	0.7	0.4
Pitch	3	0.035	10	0.7	0.7	0.4
Yaw	8	0.05	0	0.7	0.7	0.4
TPA	0.4	0.2	0.4			

Max. Deg.

Level	4	0.04	10	50
-------	---	------	----	----

KISS FC Version: 1.02 | S/N: 20303735-4D335706-00390030
show advanced configuration Save Settings

General Settings

Min. Throttle: 1070
Max. Throttle: 2000
Min. Command: 1075
Mid. Command: 1500
Tri Yaw Mid.: 1500
Tri Yaw Invert:
OneShot 125:
OneShot 42:
3D Mode:
FC Rotated by 180°:

Aux Channel Settings

AUX 1: No Action
AUX 2: No Action
AUX 3: High: Level Mode
AUX 4: Mid: Level, High: 3D
Filter: PWM5 Servo Mid, PWM5 Ser. AngX. Gain, PWM6 Servo Mid, PWM6 Ser. AngY. Gain
LPF FRQ: High: Buzzer

The AUX Channels offer access to advanced features, controlled by switches or faders on the transmitter, e.g. engaging the Level Mode or activating the buzzer like shown above. The Servo features offer functions for gimbals.

ESCs Throttle Calibration

Note: when using KISS ESC 24A you will not need to calibrate the ESCs bc of the precise onboard resonator. **Please always take off the props when using the following procedures.**

“Disarmed” always means 1000 on the KISS FC

- Connect the FC to the USB and set Min Throttle to 2000
- Arm the FC with your transmitter (without Lipo!)
- Only then connect the Lipo (beep)
- Disarm (beep)
- Unplug the Lipo again
- Set Min Throttle to 1070 (or as you need it)

Note: For safety reasons the Min Throttle settings will only become active after restarting the FC (repower)

Throttle Calibration for KISS ESCs in 3D Mode

Note: The ESC calibration only works with the KISS FC connected to the PC/GUI

1. Take off props first!
2. Activate the 3D Checkbox in the GUI -> save -> restart FC
3. Calibrate the throttle range like described above (Min Throttle is at 1500 in this case, so the ESCs will know)
4. You can now fly in Acro or Level Mode, only the range is 1500 – 2000 now.
5. Assign an AUX switch for the 3D Mode – Arm/Disarm also has to be on an AUX switch
6. Flip the 3D switch, arm the FC via switch and move the throttle stick slowly from the lowest position to the middle. The motors will now start to rotate at middle position. Always disarm the ESCs via switch – be careful: the 3D mode will always be active!

Flashing the Firmware

You will find online instructions on how to flash the latest firmware onto the FC.

http://ultraesc.de/KISSFC/update_en.html

Important! After flashing the FC you will need to reboot and connect it to the PC with internet connection. It will read your serial number and activate the FC. If the FC is not activated you will see the blue LED flashing once every second.

The boot button on the KISS FC v1.03 only needs to be pressed twice for a short period:

- a. when you plug in the USB
- b. when you confirm the "read out protection" removal (while you click)

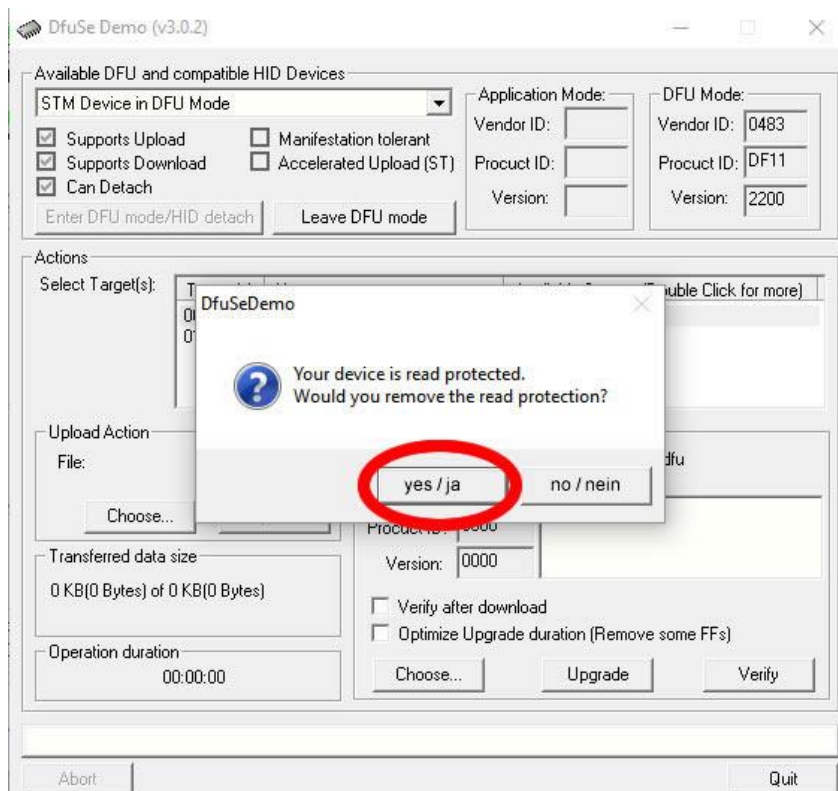

Flashing the KISS FC on a Mac



You don't have to mess around with Windows if you're more comfortable on the Mac. Do it from the Mac using the Terminal (stuff you need to copy and paste into terminal [in blue](#)). Before you do anything else, make sure you can connect to the FC in the KissFC GUI first. If not, get that sorted first since you won't be able to flash what you can't talk to.

The guide by [invid](#)* assumes that you have the Xcode IDE installed. If not, you'll need to install the command line tools:

Code:

```
Haswell:~ invid$ xcode-select --install
```

Let the install complete and accept Apple's terms of service. Once done install the Homebrew package manager that can install third party command line utilities for you like dfu-util:

```
Haswell:~ invid$ ruby -e "\$\(curl -fsSL https://raw.githubusercontent.com/Homebrew/install/master/install\)"
```

Then install dfu-util (direct firmware update utility) itself using the Brew package manager you just installed above:

```
Haswell:~ invid$ brew install dfu-util
```

You've now installed the basic command line tool environment and don't need to repeat the steps above again for future updates.

Download the firmware from Flyduino's servers and it should end up creating a folder called KISSFC_v1 in your Downloads folder. If this isn't your first firmware download you may have created a folder called KISSFC_v1-2 instead so check and adjust the command below to suit.

Change Directory to that folder in the terminal:

```
Haswell:~ invid$ cd ~/Downloads/KISSFC\_v1
```

Short the boot loader pins if you haven't already.

Unlock the EEPROM on the KISS FC so you can write the new firmware to memory - change the filename to match future firmware versions but leave the firmware options the same:

At the time of this guide the latest firmware is the beta version: KISSFC_v1.02_beta74_HWv1.02.dfu

```
Haswell:~ invid$ KISSFC\_v1 invid\$ dfu-util --alt 0 -s 0x08000000:force:unprotect -D
```

```
KISSFC\_v1.02\_beta74\_HWv1.02.dfu
```

Write the firmware to the FC, again changing the filename to match:

```
Haswell:~ invid$ KISSFC\_v1 invid\$ dfu-util -R -a 0 -D KISSFC\_v1.02\_beta74\_HWv1.02.dfu fu-util 0.8
```

Unsolder the boot pins (or release the boot loader microswitch) and reboot the FC with the new firmware. **You're done.**

***Instructions by [invid](#) taken from**

<http://www.rcgroups.com/forums/showpost.php?p=33909923&postcount=1528>

April 1st, 2016

[Table of Content](#)

Air Mode

If Min Command is set lower than TX Throttle cut, the PIC controller won't be shut off.

If Min Command is set to 1000 and the Arm function is assigned to a switch on your radio, the Air Mode is activated automatically.

In Airmode on the Ground you might find the FC trying to regulate "something" though it is sitting still. However the Airmode only makes sense in flight. On the ground some motors start to spool up. Instant take-off will avoid this effect.

Telemetry / OSD

The KISS FC offers various possibilities to use Telemetry and OSD functions
 - internal Telemetry of the FC via GUI

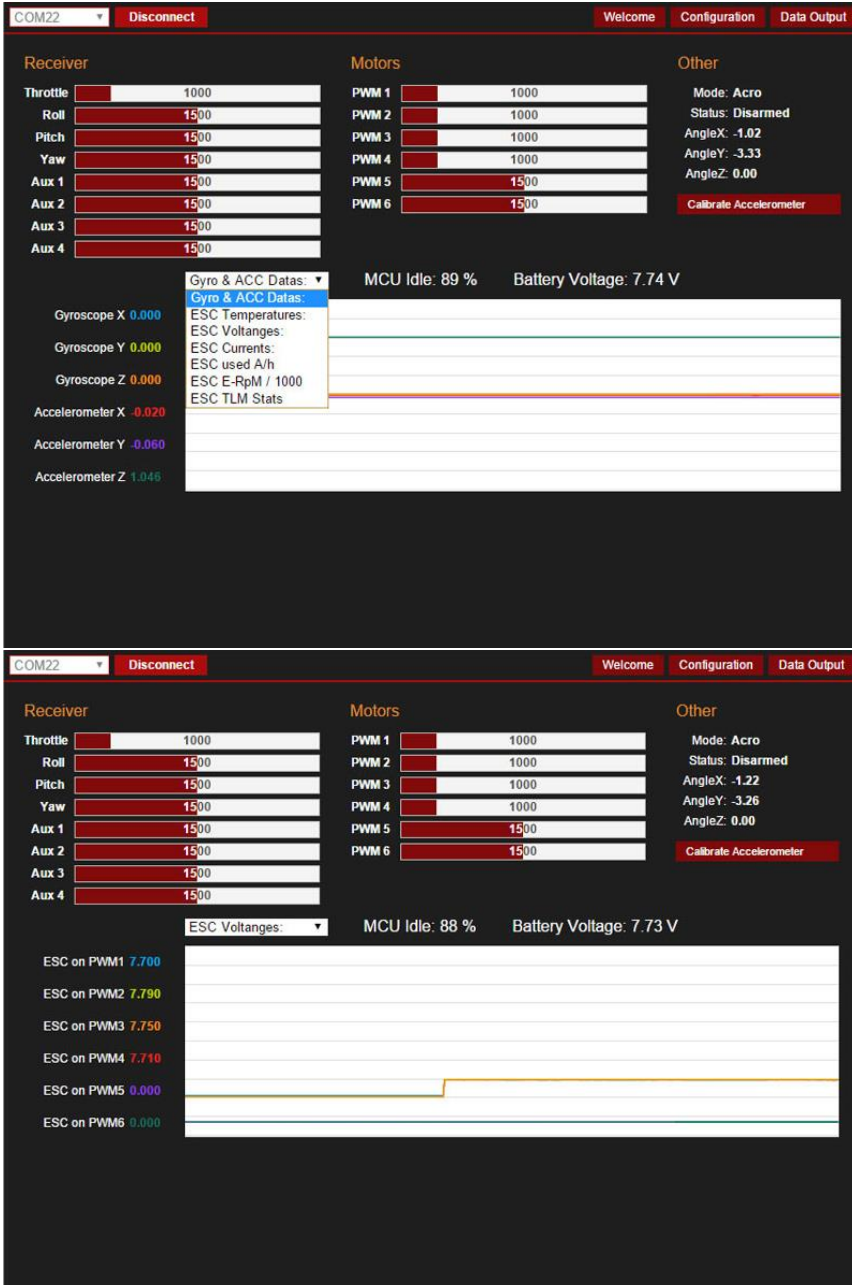

Telemetry of the KISS FC and ESC24A can be viewed on the „Data Output“ page.

- external Modules for Telemetry and OSD, e.g. KISS ESC 24A Telemetry via OSD

External Modules

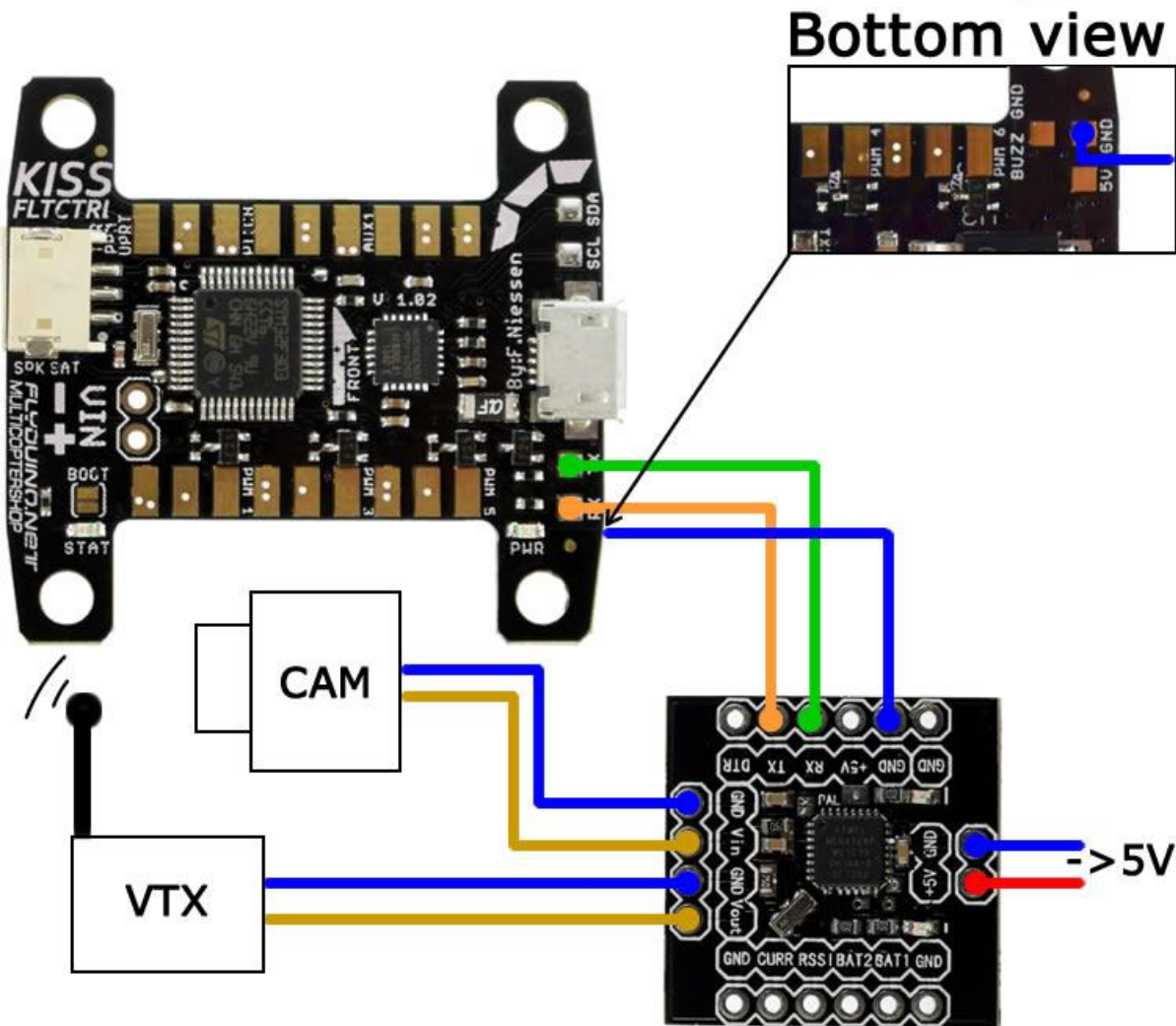

Connecting the MinimOSD – special firmware required. Actual Modules available at Flyduino.net come pre-flashed.

The OSD offers 2 Modes: “Normal” Mode with all data of the FC and the ESCs in all 4 corners and a “reduced” Mode with only the voltage and consumption.

You can assign a switch on your radio to AUX4 to toggle between the 2 Modes in flight.

As the OSD module draws a lot current you should always power it via separate supply, not through the FC.

Note: The OSD will only function properly, when the USB is disconnected. Always power the FC and ESCs first before you connect it to the USB.

Tutorials: Getting started with Arduino. We recommend using Arduino IDE v1.0.5

<https://www.arduino.cc/en/Guide/HomePage>

Telemetry for specific RC Transmitters/Receivers

FrSky Telemetry via S-Port

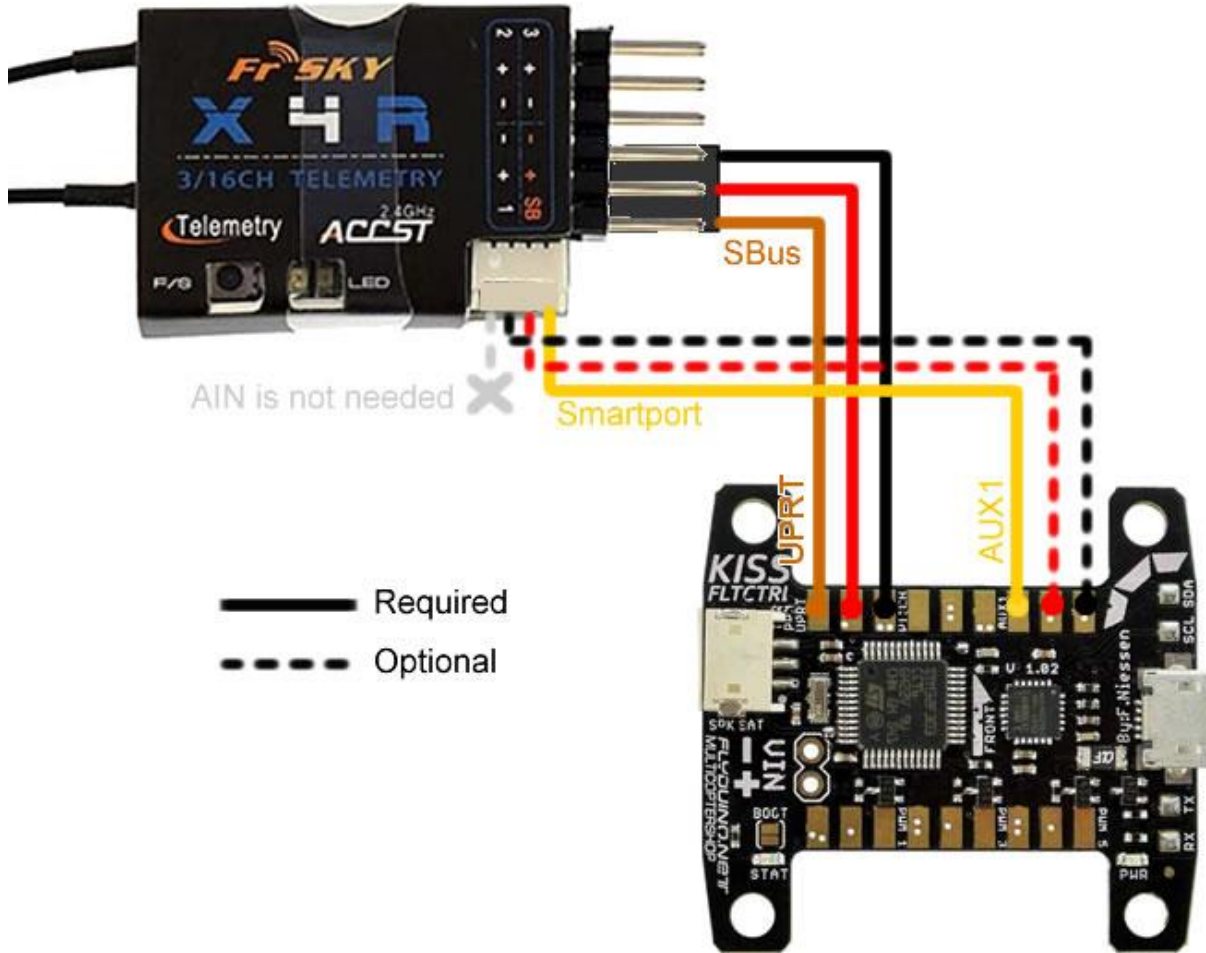

Add Sensors in the Taranis Menu

Power the FC and RX (Smartport telemetry is only active as long as FrSky SBus is selected as RX type), go to menu and then press page till you come to telemetry menu. Select "Discover new sensors". You should get beside some others the new sensors:

- VFAS (the lipo voltage in V)
- Current (the total current A)
- Fuel (the used mAh's)

Note: Current and Fuel will stay zero if you don't have supported telemetry ESC's connected (KISS24A for example)

JETI DX

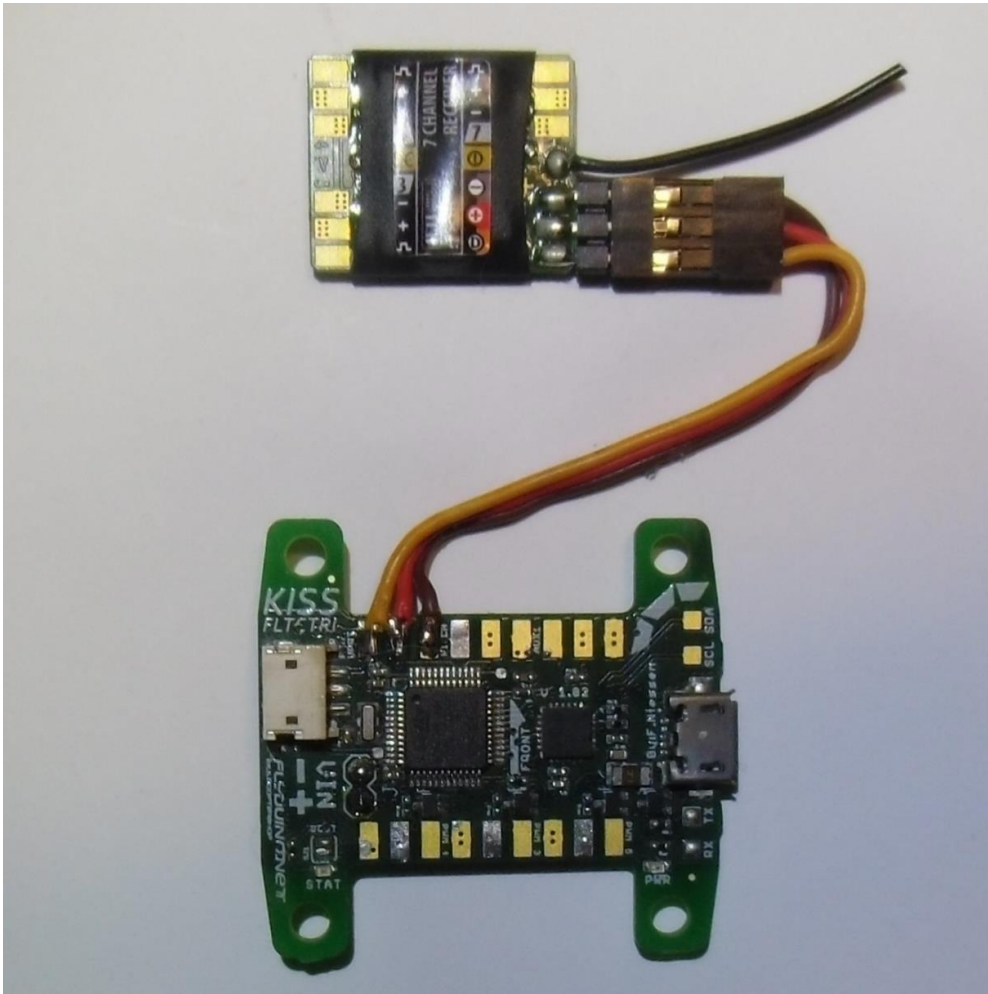

COM45
Disconnect
Welcome
Configuration
Data Output

UAV Type

Quad X

Receiver

- Jeti EX Bus
- 4-6 single Channel
- PPM:Thr.,Roll,Pitch,Yaw
- PPM:Pitch,Thr.,Roll,Yaw
- PPM:Thr.,Pitch,Yaw,Roll
- PPM:Roll,Pitch,Yaw,Thr.
- PPM:Pitch,Roll,Thr.,Yaw
- PPM:Roll,Pitch,Thr.,Yaw
- Spekt. Sat. DSM2
- Spekt. Sat. DSMX
- FrSky S-BUS
- Gr. SUMD
- Jeti EX Bus
- Futaba S-BUS
- Multiplex SRXL

	D	RC Rate	Rate	RC Curve
	10	0.7	0.7	0.4
	10	0.7	0.7	0.4
	0	0.7	0.7	0.4
				0.4

Max. Deg.

Level 4 0.04 10 50

KISS FC Version: 1.02 | S/N: 20303735-40335706-00390030

show advanced configuration

General Settings

Min. Throttle 1070

Max. Throttle 2000

Min. Command 1075

Mid. Command 1500

Tri Yaw Mid. 1500

Tri Yaw Invert

OneShot 125

OneShot 42

3D Mode

FC Rotated by 180°

Aux Channel Settings

AUX 1 No Action

AUX 2 No Action

AUX 3 No Action

AUX 4 No Action

Filter

LPF FRQ High

Save Settings

Graupner HOTT Telemetry

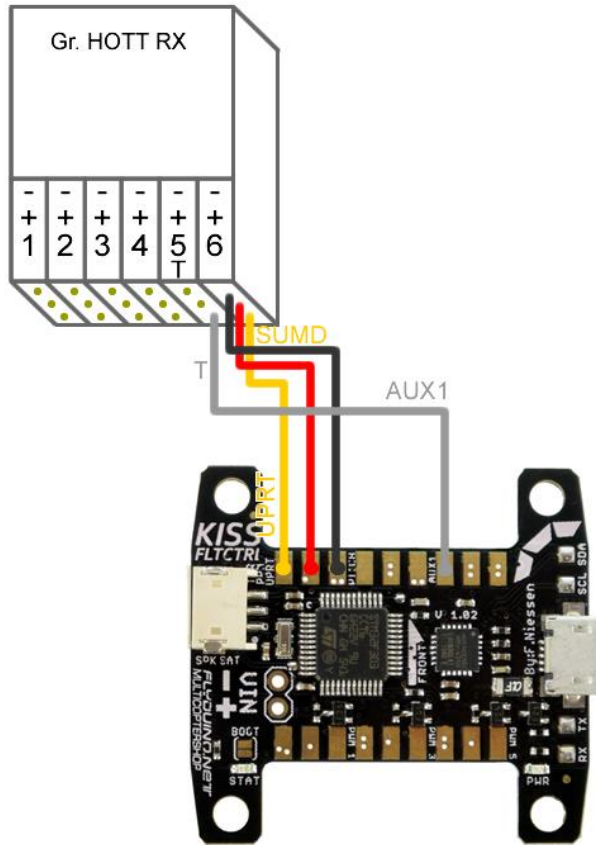

Setup your Graupner MX-xx

Power the FC and RX (HOTT telemetry is only active as long as SUMD is selected as RX type), go to Menu -> Telemetry -> RX Setup and enable SUMD and the Sensor Pin.

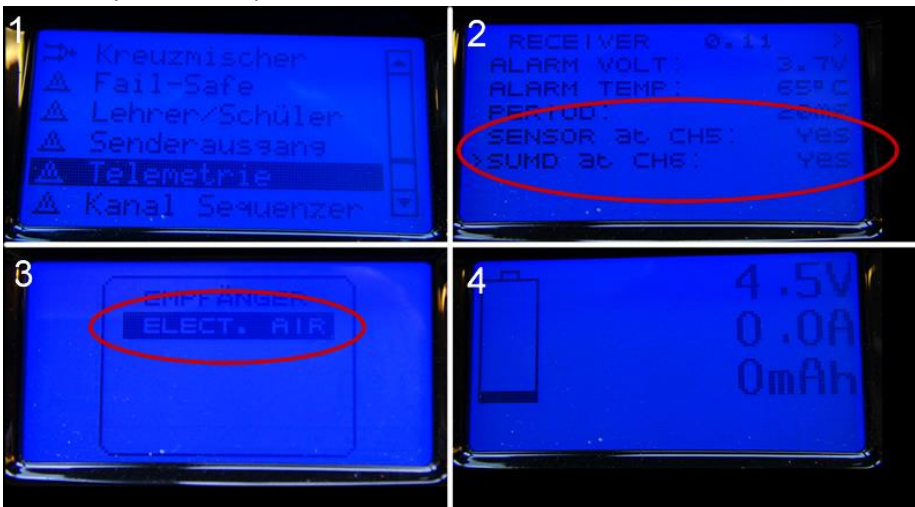

* **Note1:** To let the TX find the sensor, you should power the FC and RX close after turning on your TX. As the TX just searches for some time after it is turned on.

* **Note2:** Current (A) and the consumption (mAh) will stay zero if you don't have supported telemetry ESCs connected (KISS24A for example)

MultiPlex

The KISS FC both the digital SRXL by MultiPlex and the so called MSB Sensorbus. For using SRXL the bigger receivers you need to activate the SRXL-output. You can use the MultiPlex Launcher Software (download at MultiPlex) like shown in the screenshot or with Multimater. The smaller receivers RX-4/9 FLEXX are also tested, offering 9 channels via SRXL where the KISS FC can handle up to 8 channels.

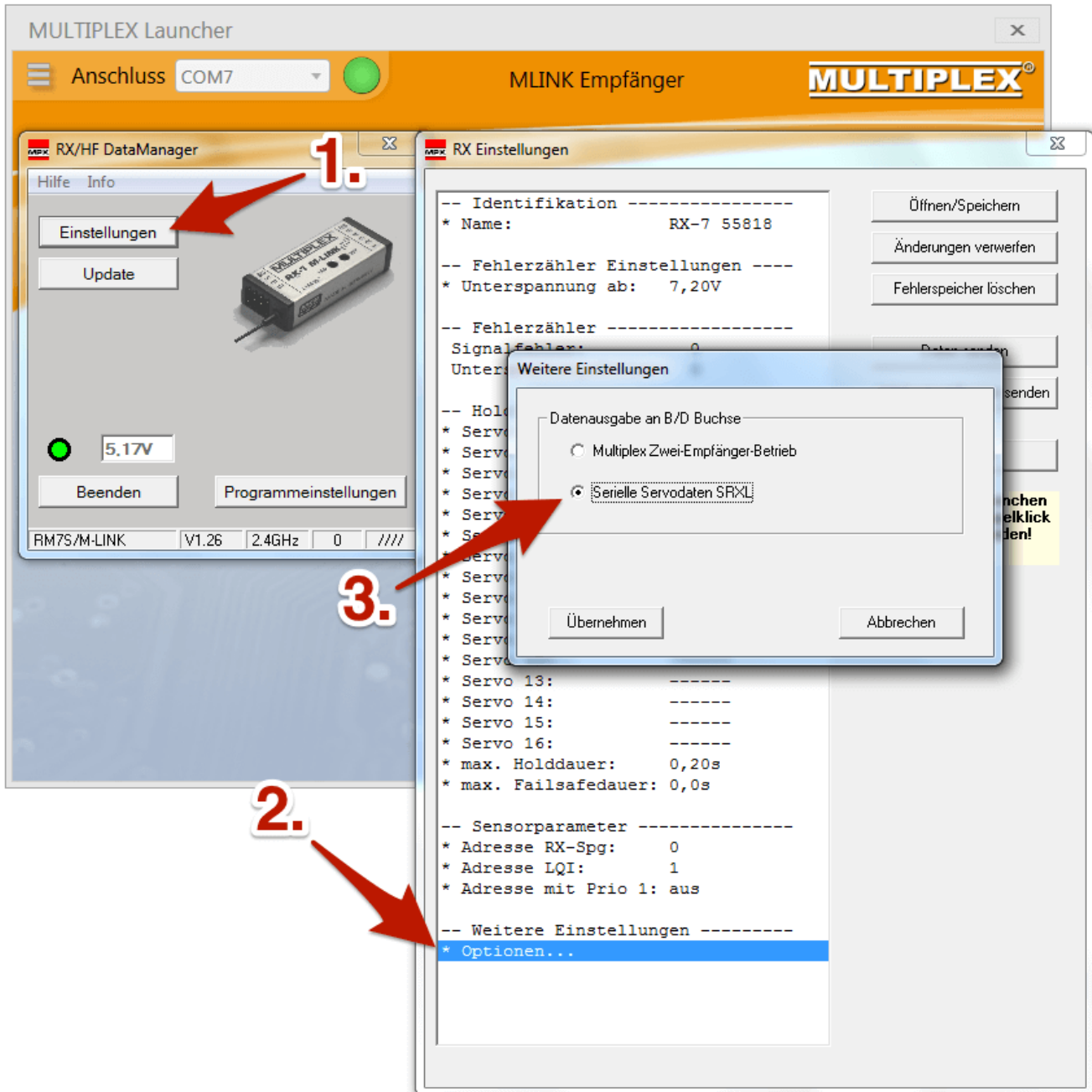

Connections

Like shown in the photo the "Throttle / PPM / UART" on the KISS FC will be connected to the Signal "B/D" on the receiver, also the 5V can be picked up here.

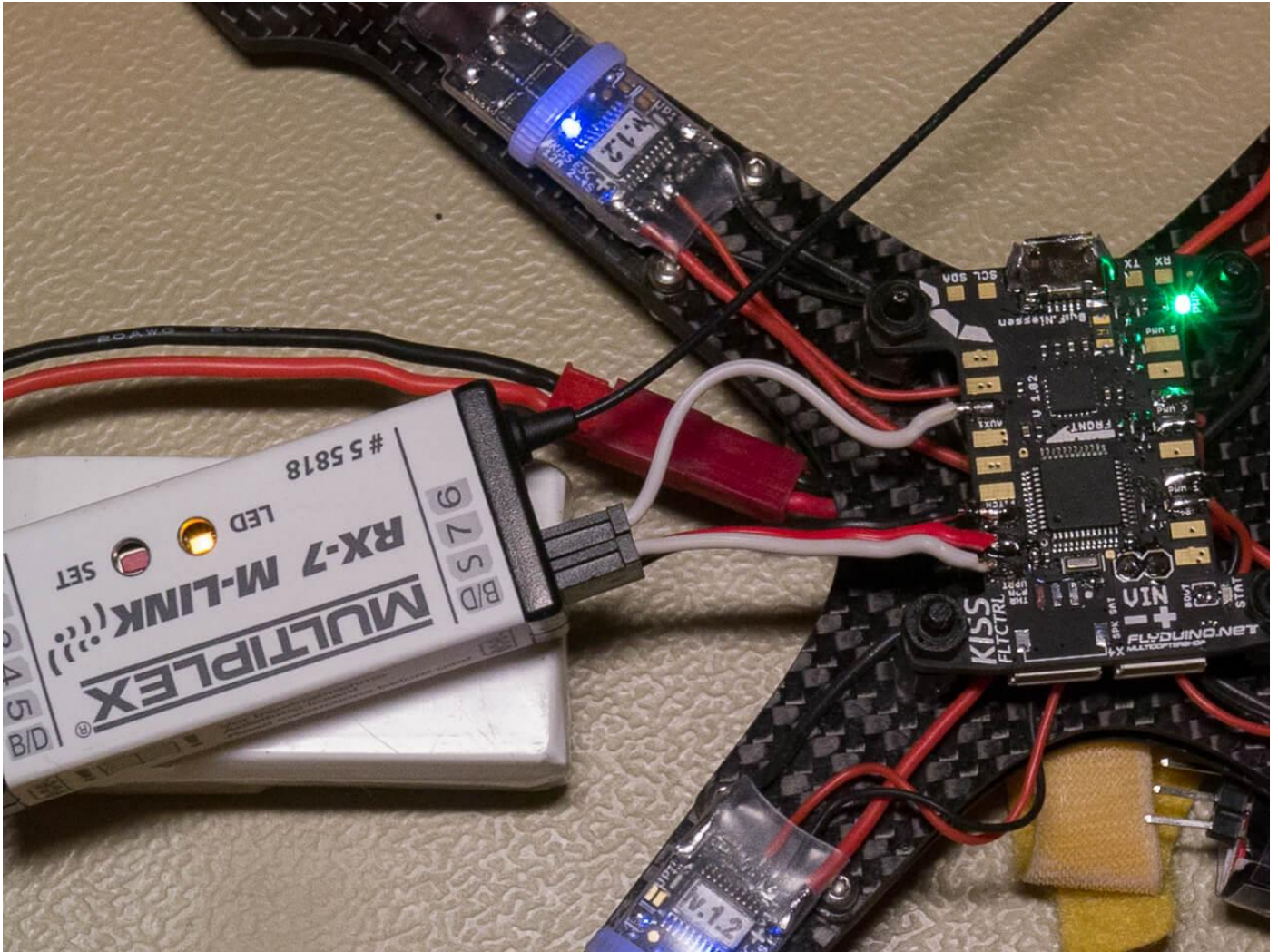

Telemetry

When you select "Multiplex" in the KISS GUI, the MSB-support will automatically be activated. Connect "AUX1" on the KISS FC with the "S" port on the receiver like shown in the image above.

Examples for external Modules

- Micro MinimOSD

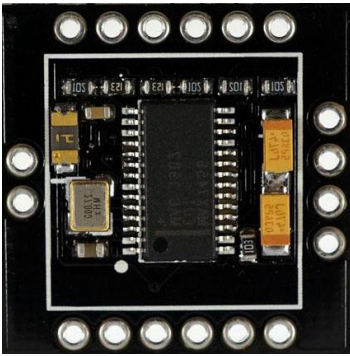

Refer to the connection diagram above. <https://flyduino.net/Micro-MinimOSD>

- DIY Voltage Divider



How to build a voltage divider: <https://www.youtube.com/watch?v=21HhyyQB2RI>

- FrSky Voltage Sensor



Can be purchased at various stores online for ~5\$, e.g. at Flyduino: http://flyduino.net/Frsky-FBVS-01-FrSky-Battery-Voltage-Sensor_1

Bluetooth Connection



You can use such a BlueTooth2 module (HC-05) that comes preconfigured as a slave module with 115200 Baud rate and a 5V regulator.

Bottom view

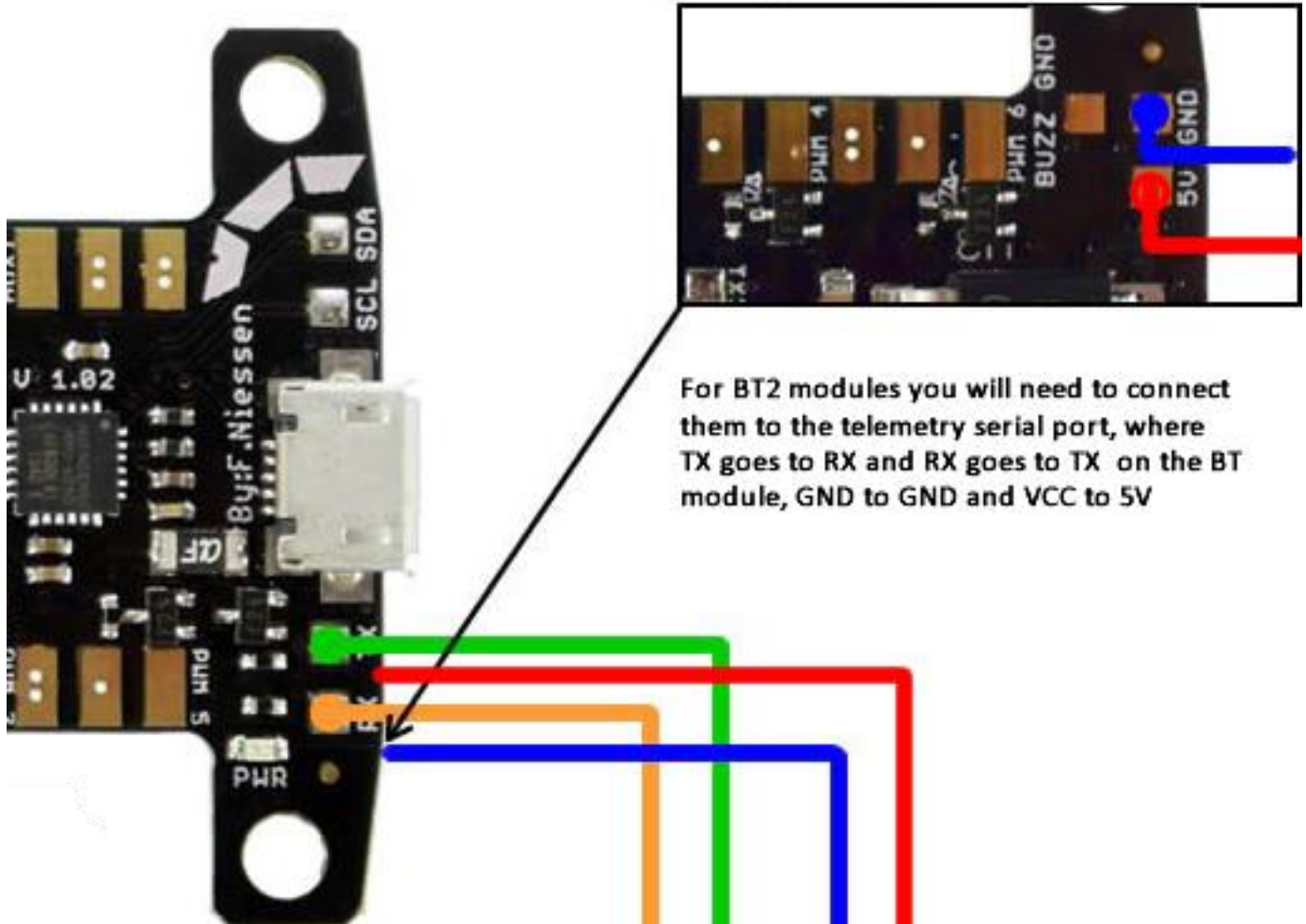

They will connect both to mobile devices like Android and iOS or with the Chrome App to Windows, Mac and Linux PCs as they provide a serial com port for connection. You can order such a module from Flyduino: <http://flyduino.net/Serial-Bluetooth-Adapter-PlugnPlay-for-Android-App>



Another solution would be a more modern BLE Bluetooth 4 module (HM-11) but they don't provide an SPP serial com port so they can only be used for direct BT connections for mobile devices such as Android 4.x Most of them come with a default baud rate of 9600 baud. These modules need to be connected to the 3.3V pad of the FC.

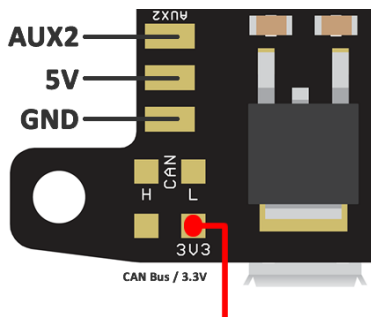

For further questions and discussions please follow us on RCGroups:

<http://www.rcgroups.com/forums/showthread.php?t=2555204>



Flyduino, Paul Bake
Süderfeldstr. 54
22529 Hamburg
Email: info@flyduino.net