

Eclipse 009Dual-HD

Quick Start Guide

V1.0

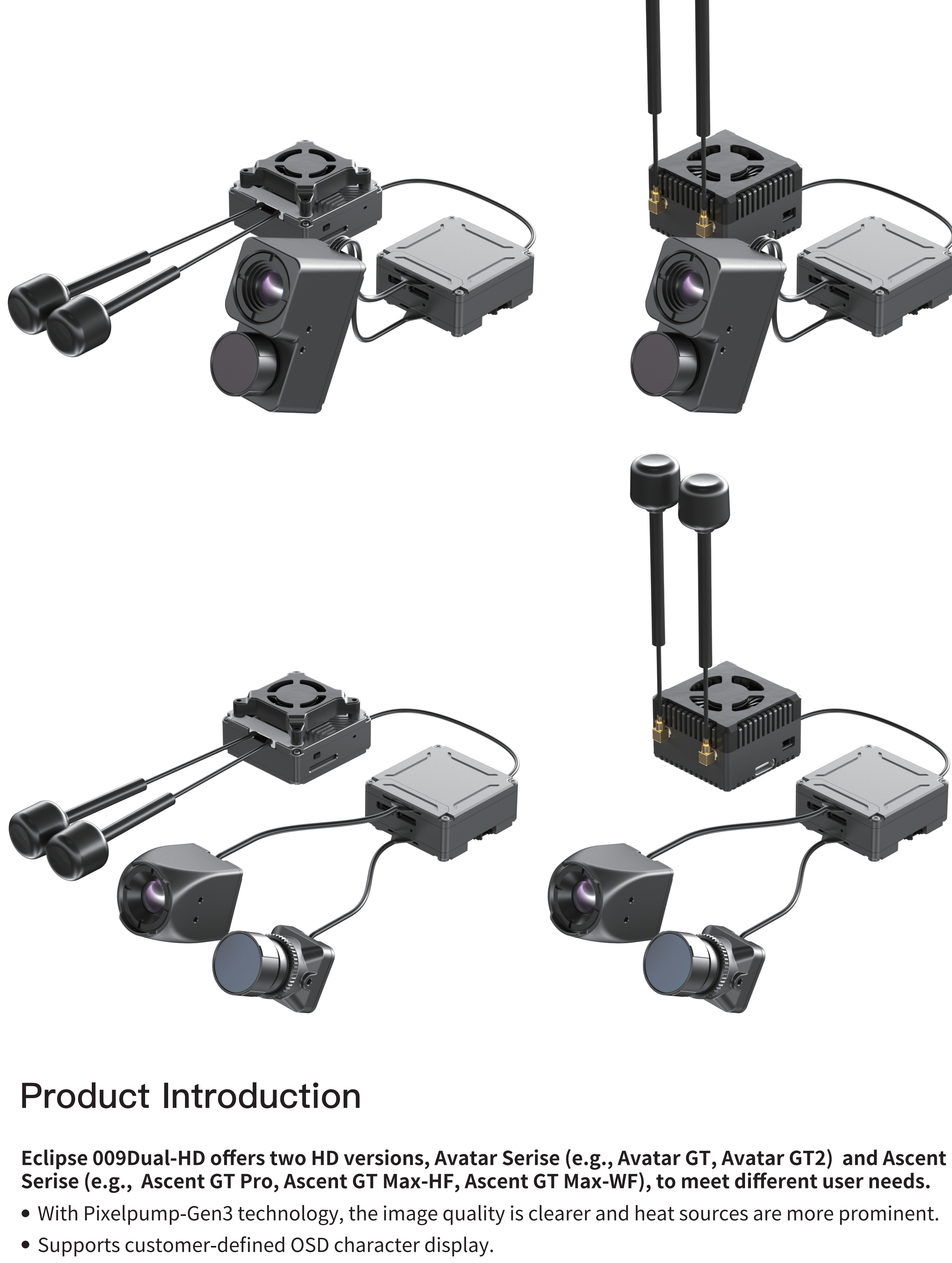

Product Introduction

Eclipse 009Dual-HD offers two HD versions, Avatar Serie (e.g., Avatar GT, Avatar GT2) and Ascent Serie (e.g., Ascent GT Pro, Ascent GT Max-HF, Ascent GT Max-WF), to meet different user needs.

- With Pixelpump-Gen3 technology, the image quality is clearer and heat sources are more prominent.
- Supports customer-defined OSD character display.
- Supports UVC video output.

The third-generation Pixelpump-Gen3 technology.

Equipped with the third-generation Pixelpump-Gen3 technology, the Eclipse 009Dual-HD delivers a significant advantage in image clarity when paired with an HD transmission system, offering richer and more detailed visuals.

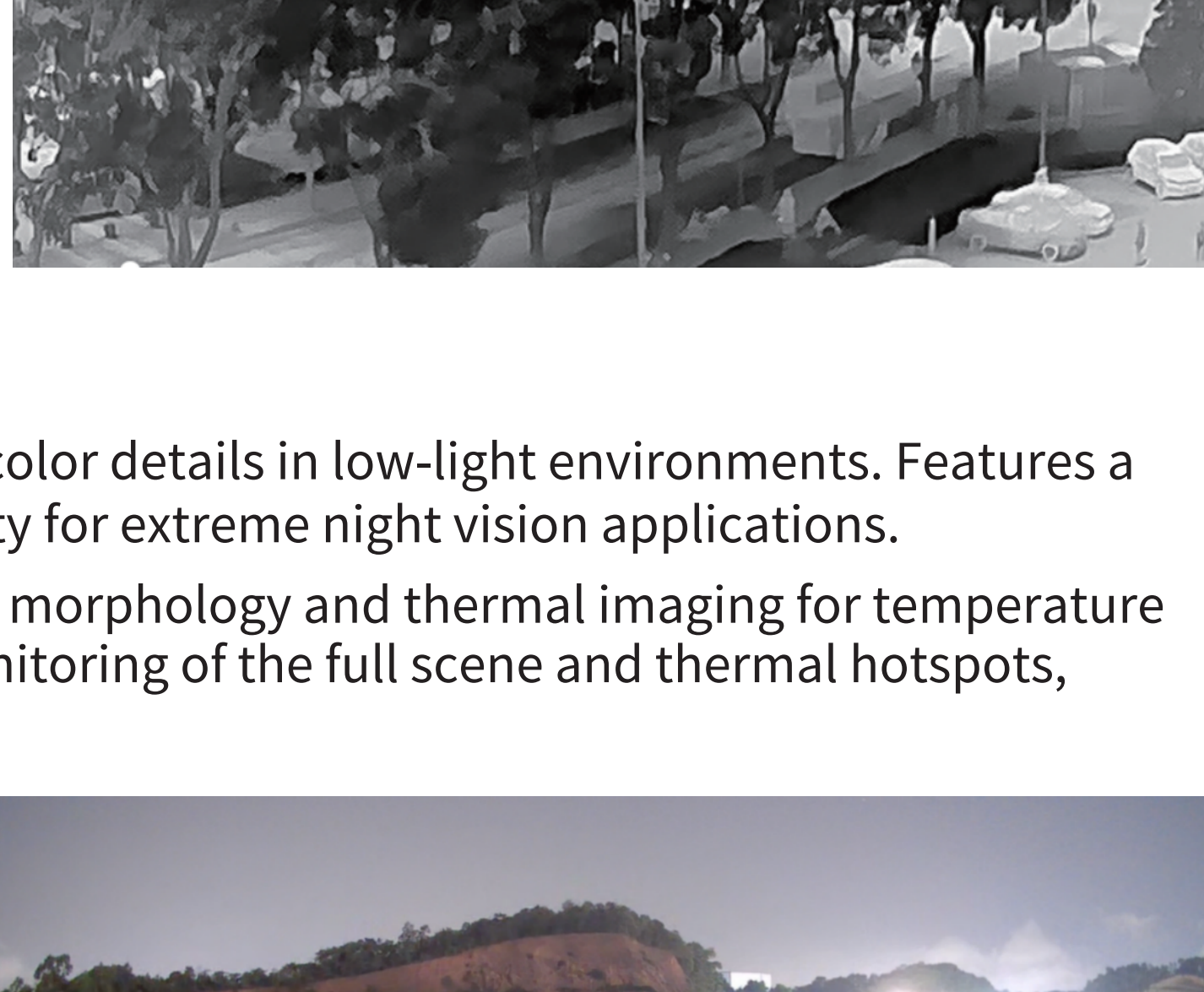

Imaging powered by Pixelpump-Gen3 technology

Full-Color Night Vision & PIP Mode:

- Visible Light Full-Color Night Vision: Maintains rich color details in low-light environments. Features a manual filter removal function to enhance sensitivity for extreme night vision applications.
- Fusion Picture-in-Picture: Combines visible light for morphology and thermal imaging for temperature detection. The PIP display allows simultaneous monitoring of the full scene and thermal hotspots, ensuring rapid and accurate situational awareness.

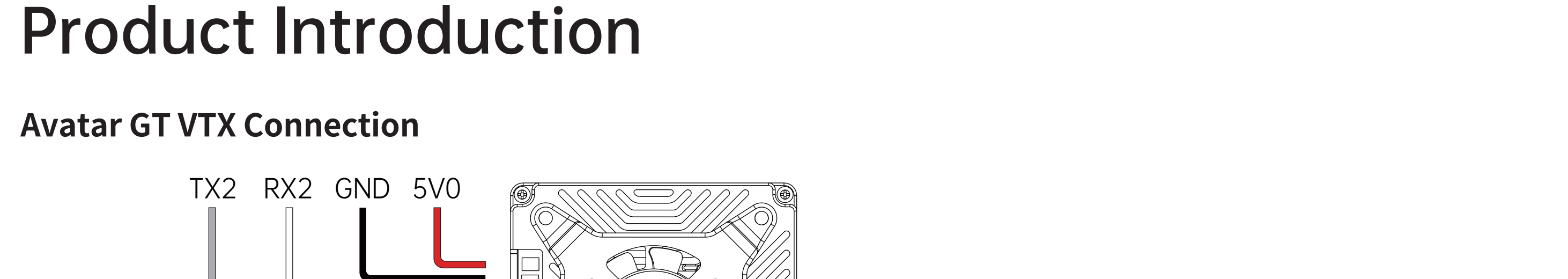

Product Introduction

Avatar GT VTX Connection

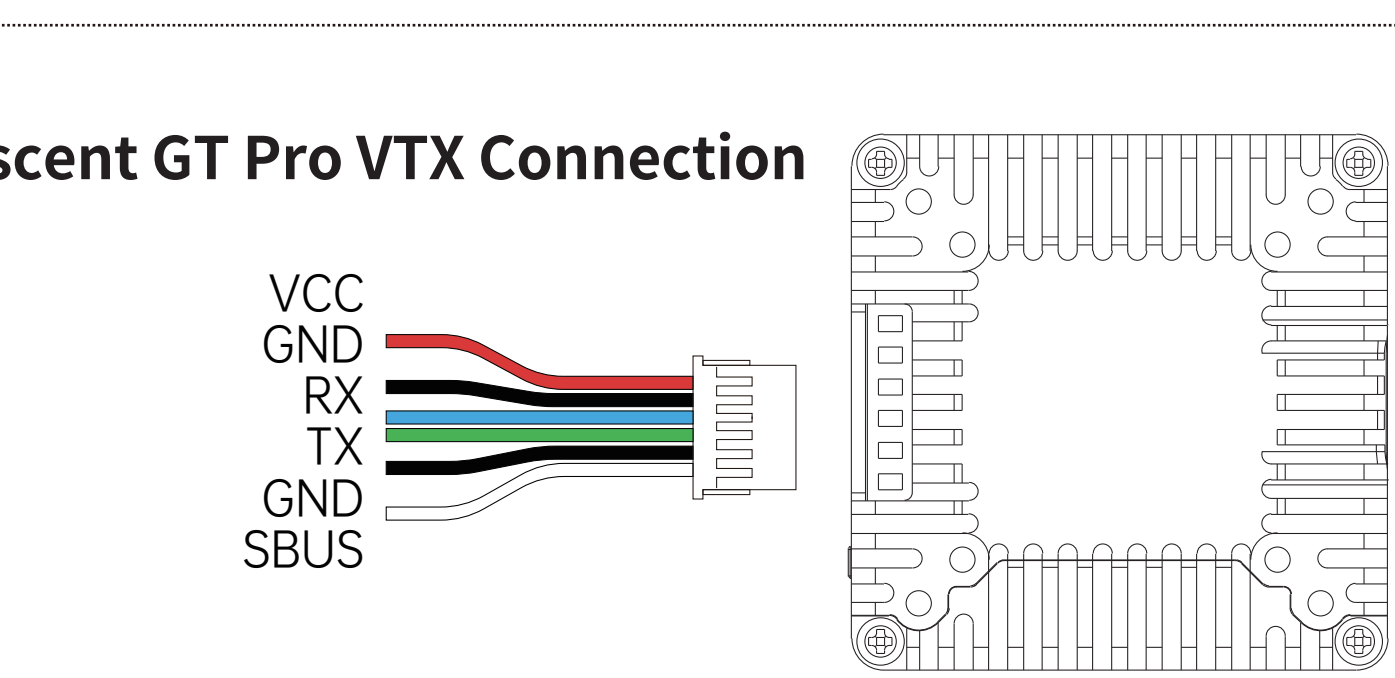

- ⚠ Power consumption: 12V@1.5A.
- Please consider the power supply capability of the power supply. VTX generates a lot of heat when working, so please pay attention to airflow for heat dissipation.

Ascent GT Pro VTX Connection

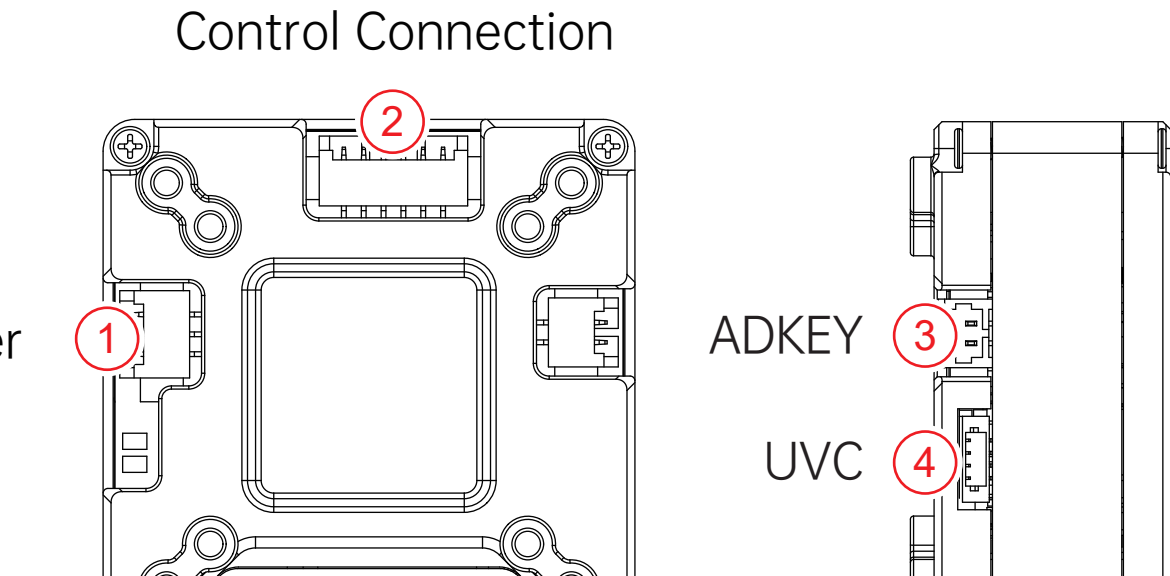

- ⚠ Power consumption: 12V@1.5A.
- Please consider the power supply capability of the power supply. VTX generates a lot of heat when working, so please pay attention to airflow for heat dissipation.

AI Box Connection

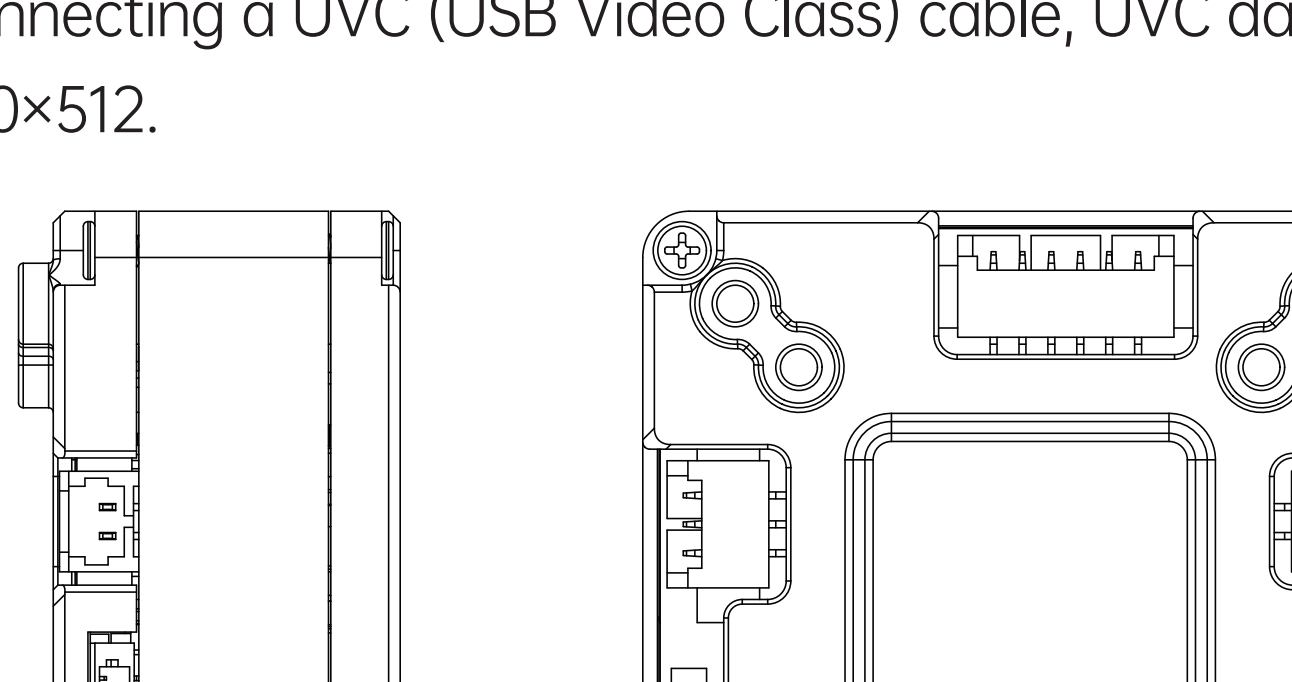

- ⚠ Power Consumption: 12V@120mAh

UVC Function

By connecting a UVC (USB Video Class) cable, UVC data output is supported in MJPEG format with a resolution of 640x512.

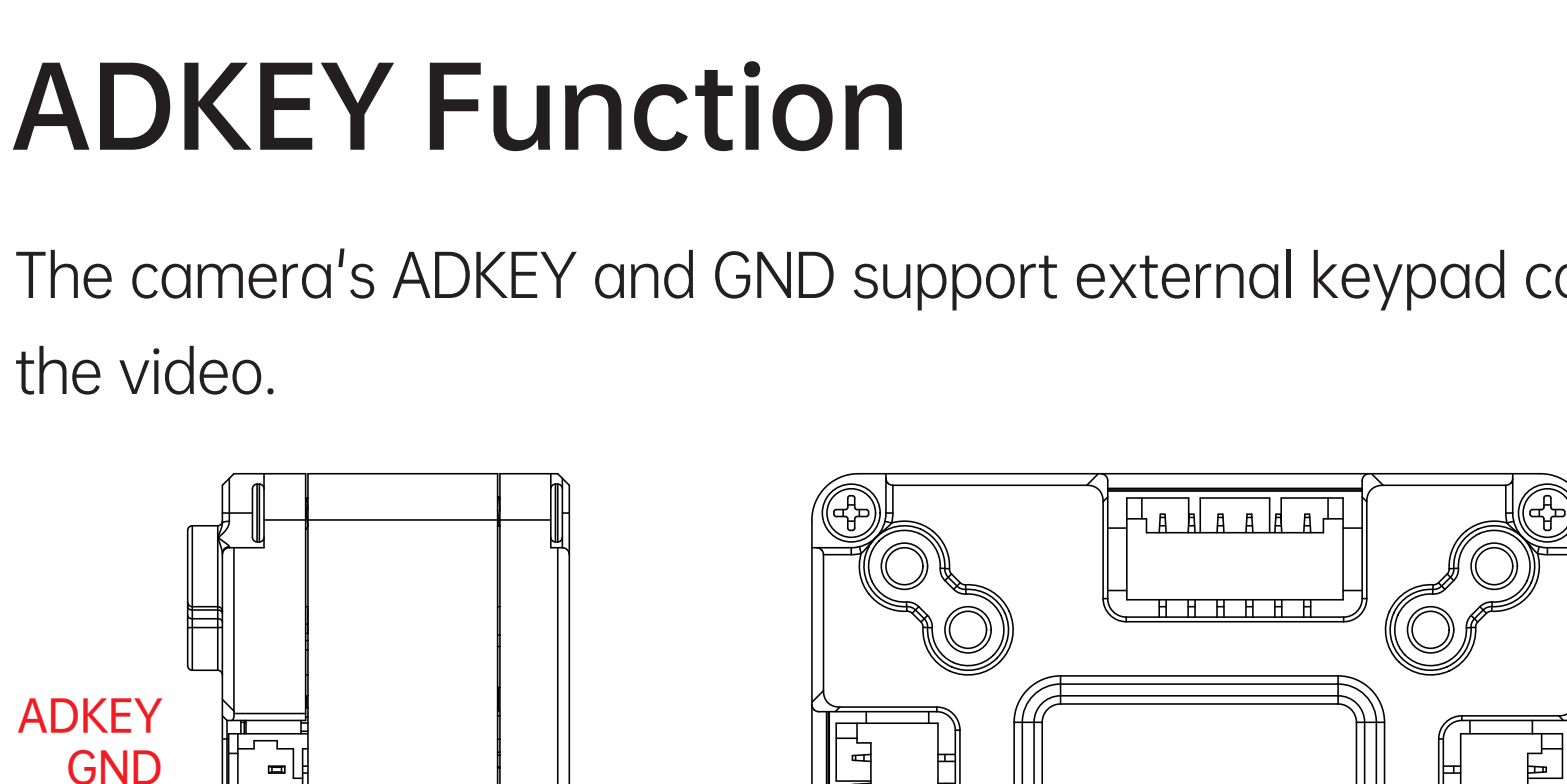

Dynamic adjustment is implemented through the Processing Unit (PU) control defined by the UVC protocol, where the brightness adjustment interface is UVC_PU_BRIGHTNESS_CONTROL, the contrast adjustment interface is UVC_PU_CONTRAST_CONTROL, and the pseudo-color adjustment interface is UVC_PU_HUE_CONTROL.

ADKEY Function

The camera's ADKEY and GND support external keypad connection for customizing OSD strings displayed on the video.



OSDMenu Board
*Short press the middle button on the menu board to enter OSD settings. Remove the OSD menu board after completing the settings.



The menu board provides an intuitive operation experience through the ADKEY interface: short press to enter the menu, use the up and down keys to select functions, and the left and right keys to adjust parameter values. Adjustable parameters include contrast, brightness, pseudo color, image rotation, image style, and other display settings.

Switch Control

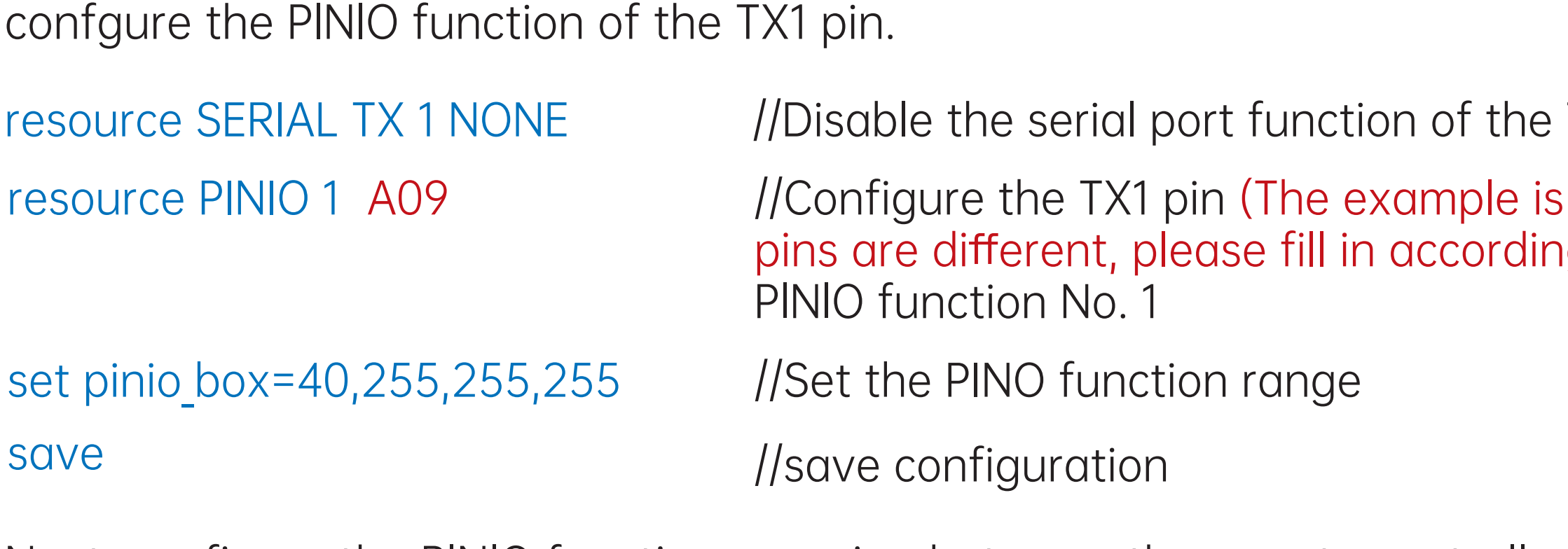

Use the remote controller to remotely switch the display of the visible light camera and the black & white camera. Take the commonly used Betaflight F405 FC as an example to explain how to configure the remote control switching function. Take the FC TX1 port as an example, make sure the UART1 function is not used, and solder the control line (Introduction 4) to the FC TX1 port.

Open Betaflight Configurator, and enter `resource` in the CLI command line to query the TX1 pin definition. The TX1 of the demonstration FC is the A09 pin. Enter the following blue font to configure the PINIO function of the TX1 pin.

```
resource SERIAL TX 1 NONE //Disable the serial port function of the Tx1 pin
resource PINIO 1 A09 //Configure the TX1 pin (The example is A09 pin, different FC pins are different, please fill in according to the actual) as PINIO function No. 1
set pinio_box=40,255,255,255 //Set the PINO function range
save //save configuration
```

Next, configure the PINIO function mapping between the remote controller and FC. In Betaflight Configuration, map the No.1 PINIO function (ie USER1 in the figure below) to the AUX channel of the remote control.

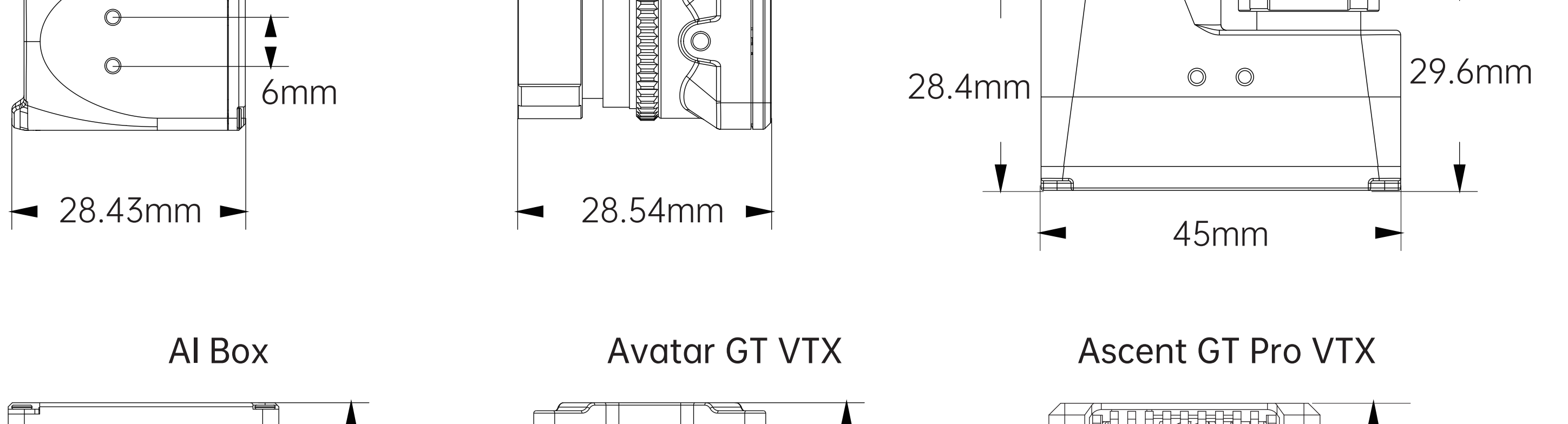

The cursor in the white area shows the visible light camera, and the cursor in the yellow area shows the thermal imaging camera.

Dimension

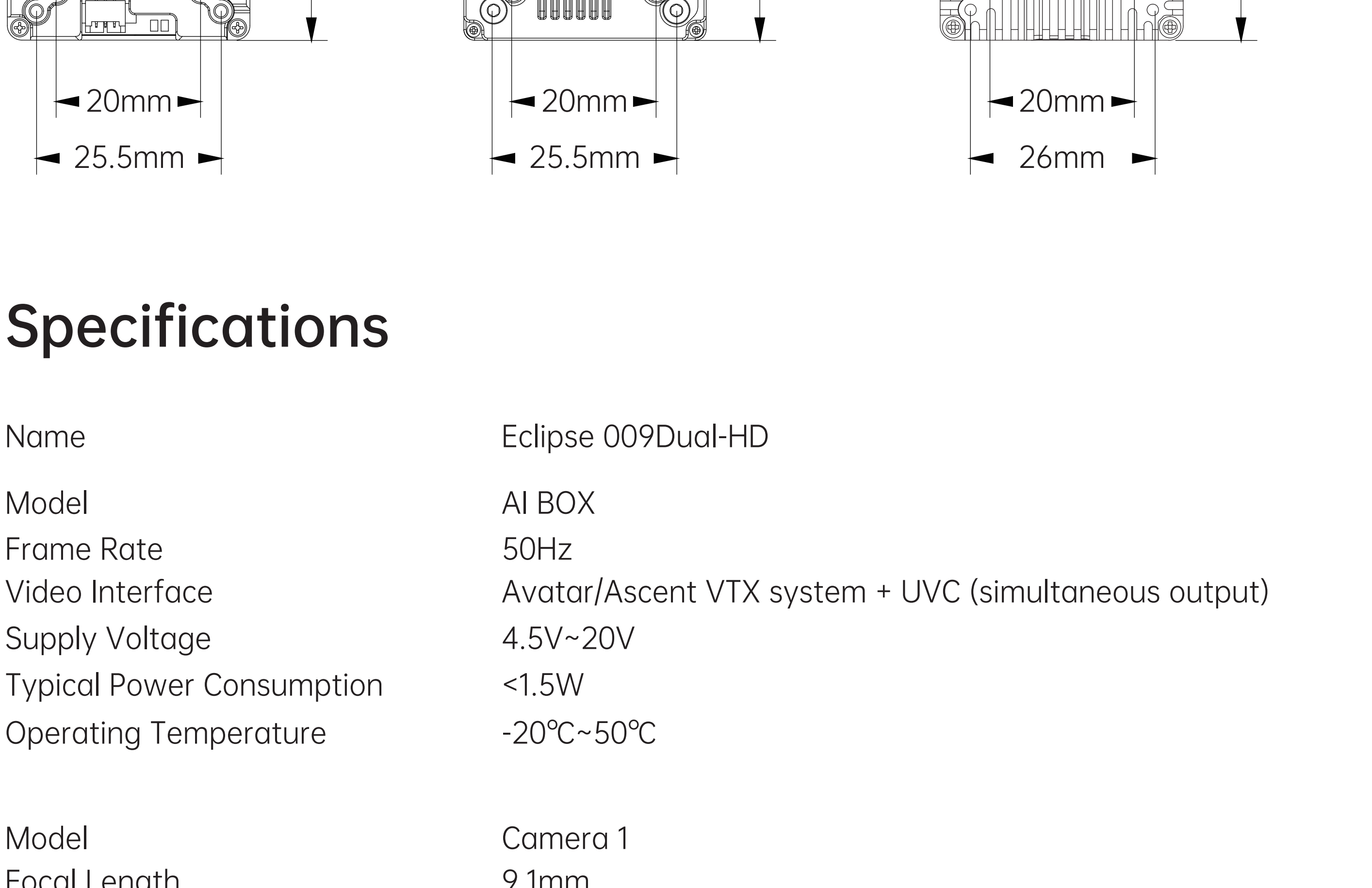

Specifications

Name	Eclipse 009Dual-HD
Model	AI BOX
Frame Rate	50Hz
Video Resolution	Avatar/Ascent VTX system + UVC (simultaneous output)
Supply Voltage	4.5V~20V
Typical Power Consumption	<1.5W
Operating Temperature	-20°C~50°C
Model	Camera 1
Focal Length	9.1mm
Resolution	960*768 (Pixelpump)
Focal Length	9.1mm
F.NO	F1.0
FOV	48.3°(H)*38.6°(V)
Communication Interface	UVC/ ADKEY
Brightness/Contrast	0-100 Optional
Palette	0-4 Optional
Digital Zoom	1.0~4.0× stepless zoom (controllable via UVC)
Image Mirroring	Horizontal / Vertical / Diagonal
Model	Camera 2
FOV	131.6°
Focal length	2.8mm
Aperture	16:9
Filter	Manually removable