

# DRAGON-TALON MANUAL

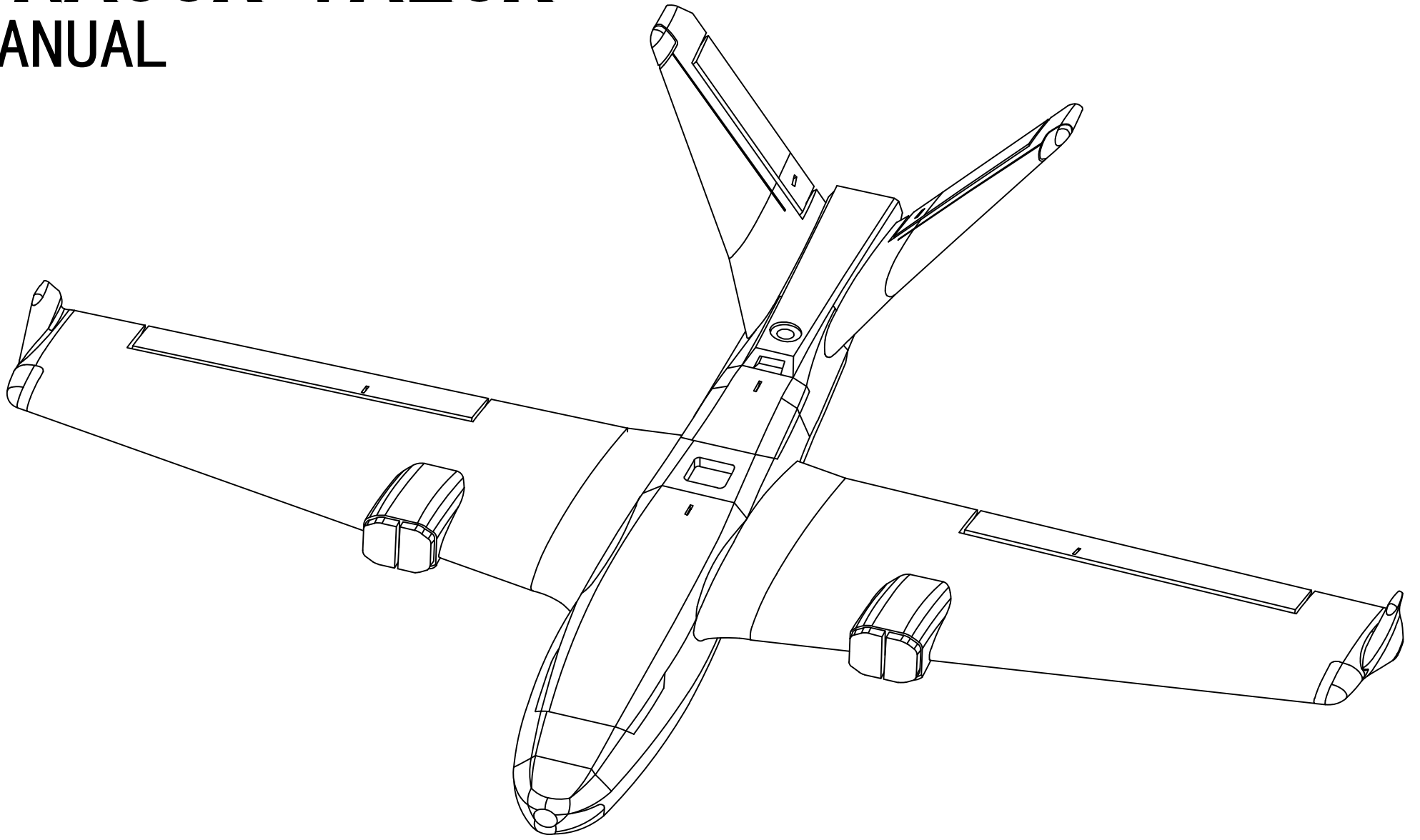

## Decomposition diagram

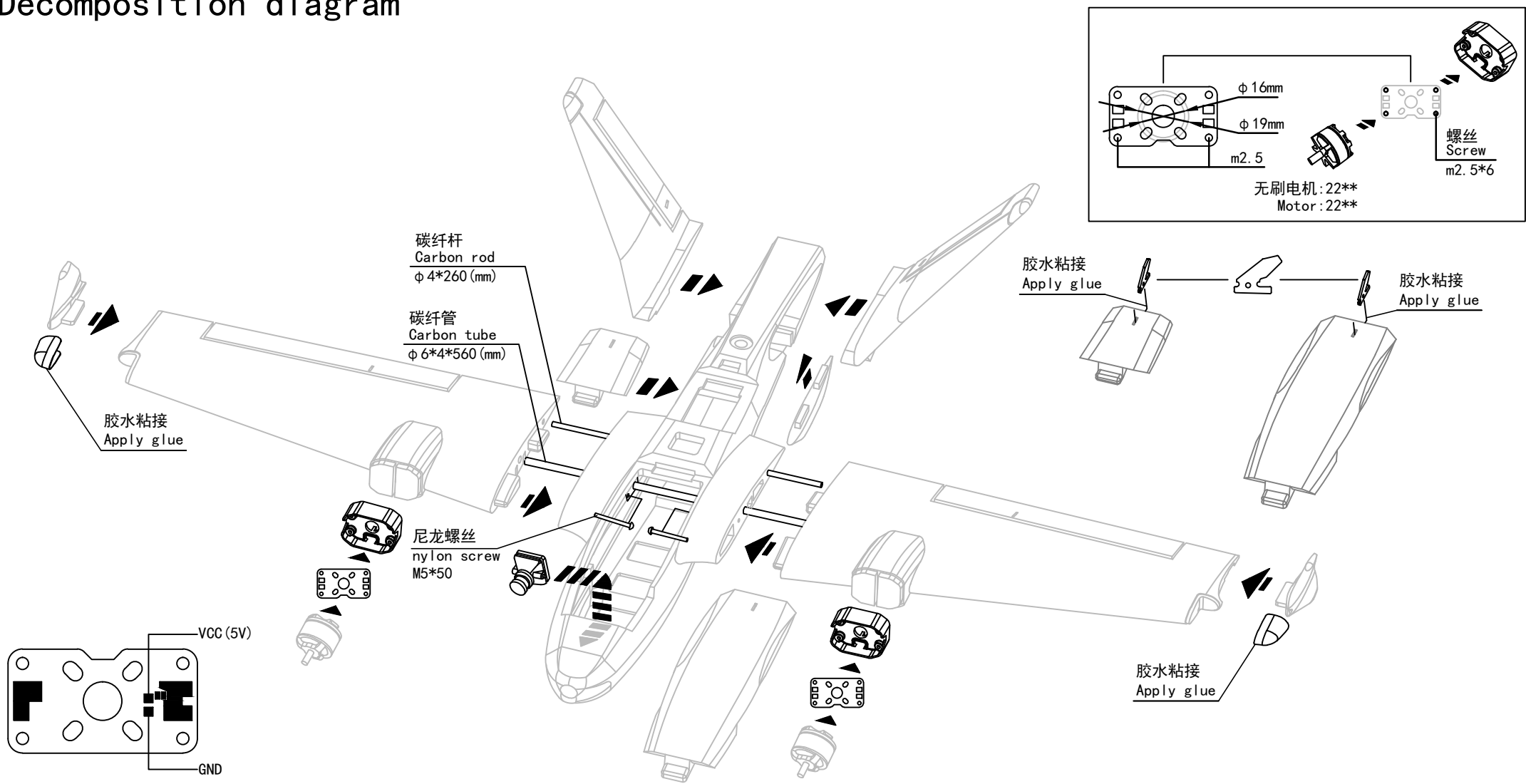

**WARNING!**  
This product is NOT a toy. Adult supervision is required for those under 14 years old.

**WARNING:** Read the ENTIRE instruction manual to become familiar with the features of the product before operating. Failure to operate the product correctly can result in damage to the product, personal property and cause serious injury. This is a sophisticated hobby product. It must be operated with caution and common sense and requires some basic mechanical ability. Failure to operate this Product in a safe and responsible manner could result in injury or damage to the product or other property. This product is not intended for use by children without direct adult supervision.

# Pull rod installation

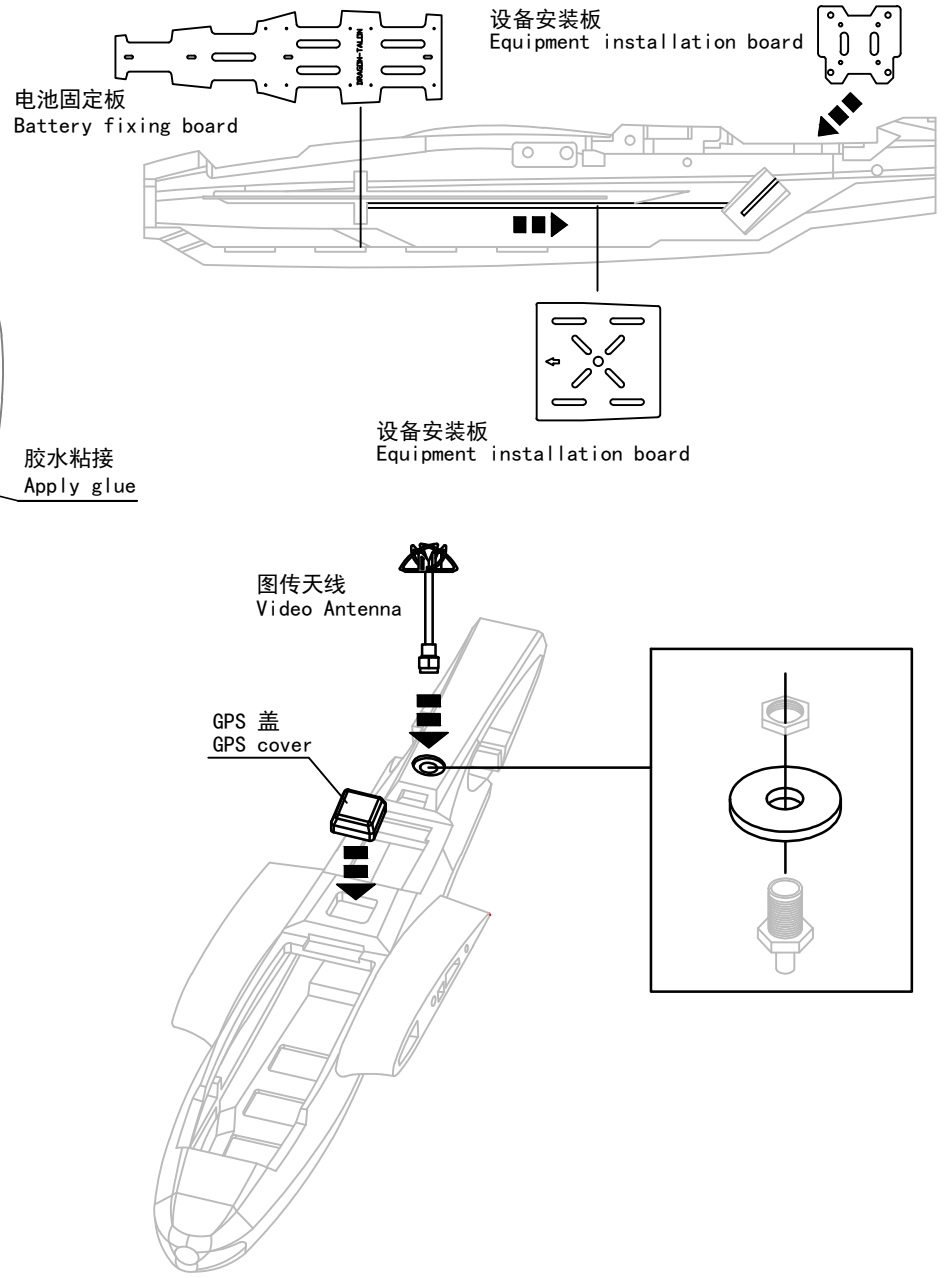
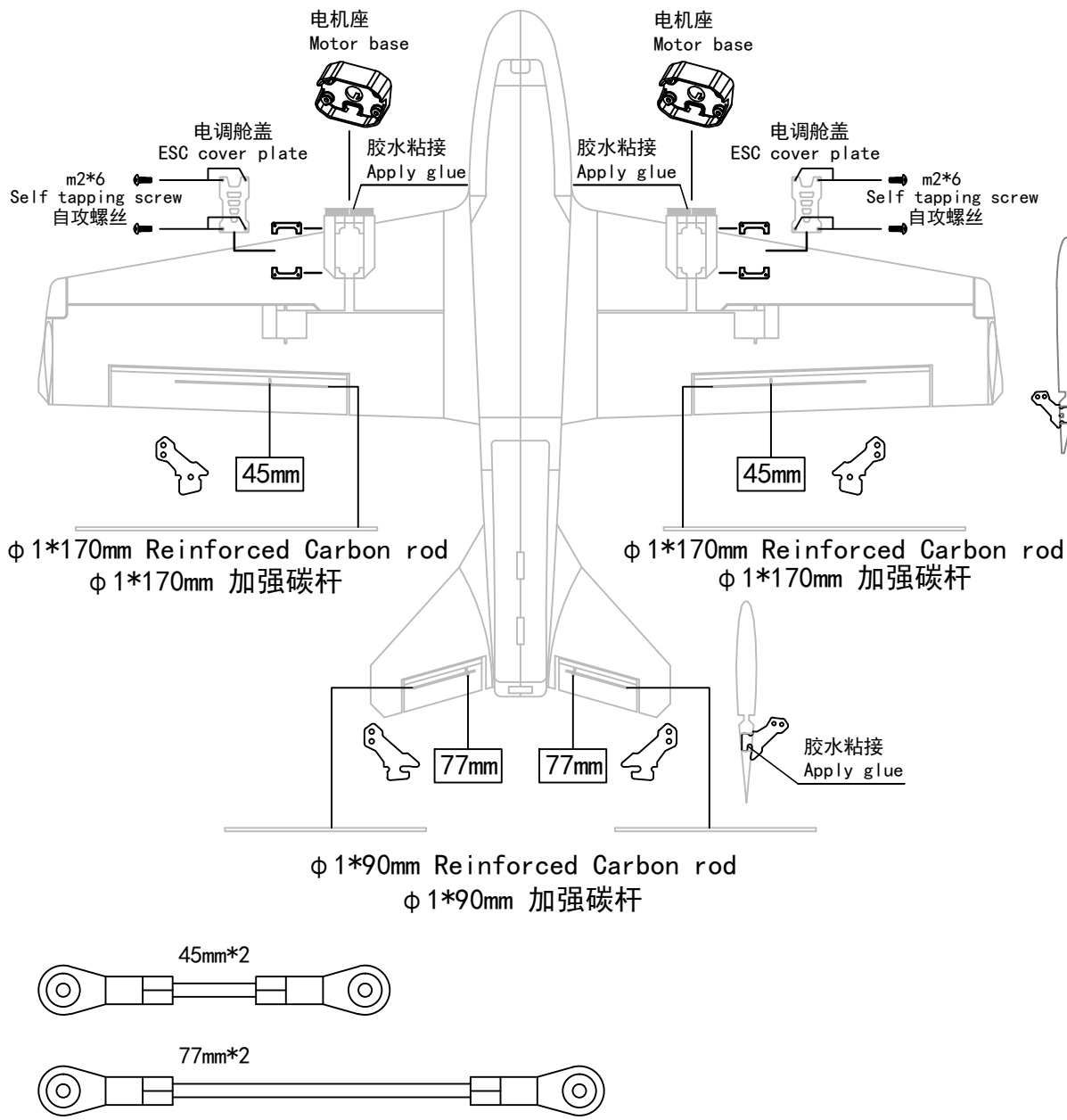

## Technical data Specifications Table

Wingspan	800mm
Length	580mm
Weight	220g (Without electronic equipment)
Wing size	10.4DM <sup>2</sup>
Flying weight	700g

## Recommended Table

Motor	2205*2
ESC	30A-40A
Servo	9g*4PCS
Propeller	5inch
LiPO battery	11.1V 3S 14.8V 4S
Radio	4 channels with elevon mixing

Please select the appropriate propeller according to the motor specification table.

## Sticker diagram

