

# 1.3GHz 4W Video Transmitter

## SPECIFICATION

REV. A      DATE 12-05-2024

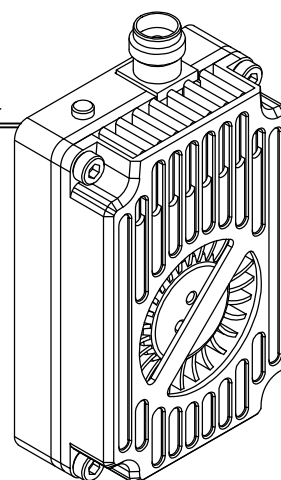

### Features

- Designed for long-range flights, up to 4W transmitting power, and provide multi-level adjustment.
- Efficient PA and power calibration to ensure power consistency across all channels.
- Customized digital PLL circuit, chip level integration, no frequency drift.
- Built-in bandpass filter to reduce harmonic interference to navigation equipment.
- Aluminum alloy three-layer shell structure and large centrifugal fan provide sufficient heat dissipation to ensure stable output of transmitting power.

### Diagrams

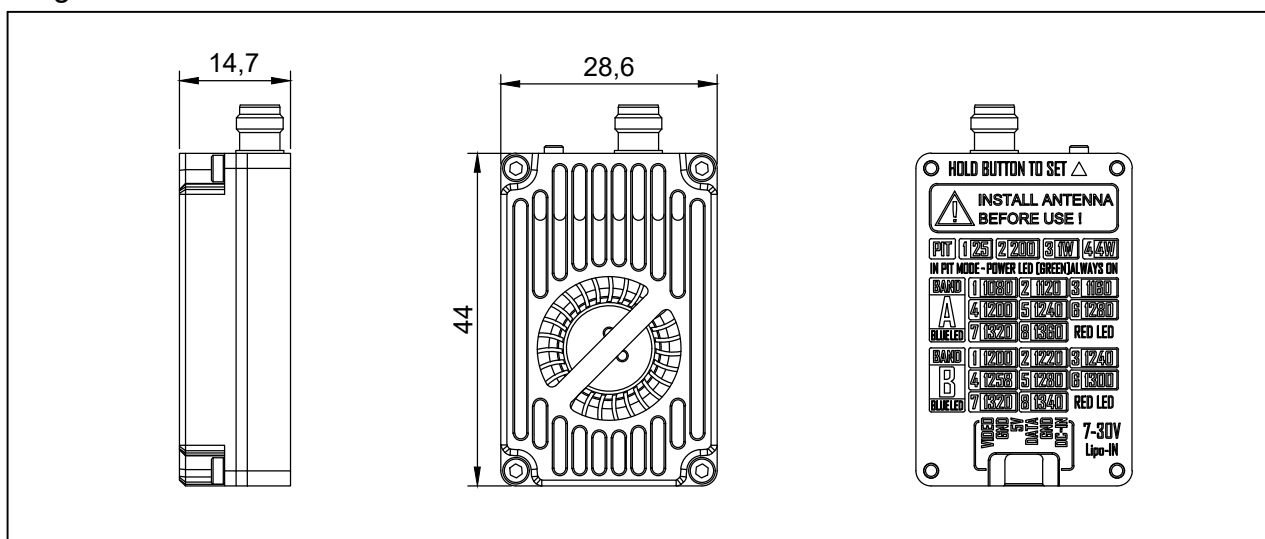

### General Characteristics

Frequency band	1080-1360MHz	Frequency precision	±200KHz (Typ.)
Channel customer	16	S/N(For ±3MHz)	>70dBc
Modulation type	FM	Antenna Port	SMA 50 Ohms
Frequency control	PLL	Video input level	1V±0.2Vp-p (typ.)
Frequency stability	±100KHz (Typ.)	Operating Temperature	-10℃~+70℃
Power Supply	DC 7-30V	Control Protocol	IRC Tramp

### RF output

	CH1	CH2	CH3	CH4	CH5	CH6	CH7	CH8
1G3 BAND A	1080	1120	1160	1200	1240	1280	1320	1360
1G3 BAND B	1200	1220	1240	1258	1280	1300	1320	1340

\*Provide 1.4GHz-2.8GHz any band customization, the maximum working bandwidth is limited to 300MHz.

Power Level	0	1	2	3	4
Values	PIT	25mW	200mW	1000mW	4000mW
Min.	-30dBm	11dBm	21dBm	29dBm	35.5dBm
Typ.	-28dBm	14dBm	23dBm	30dBm	36dBm
Max.	-26dBm	17dBm	25dBm	31dBm	36.5dBm
Current @12V	160mA	270mA	420mA	780mA	1400mA

## Wiring

Antenna must be connected before use! Otherwise there is a risk of damage to the product.  
 The product needs to be mounted reliably, avoiding vibration and high temperatures.  
 The product has a built-in power filter, but still need to avoid excessive power supply interference.

## Settings

Controlled using a single button, the button integrates RGB lighting, **blue for band**, **red for channel**, and **green for power level**.

When there is no operation, the RGB LED blinks cyclically, the number of times the RGB blinks represents the current VTX status (when the green LED is **always on**, the VTX enters PITMODE).

**Long press** the button to enter VTX setting, at this time the RGB lights are lit alternately, release the button under the corresponding color light to enter the corresponding function setting. At this time, **short press** the button to adjust the value.

For setup via the flight controller, connect the DATA pin and use the IRC Trump protocol.

## Transmitter antenna

\*All brand name logos have been removed.

Polarization	RHCP	Gain	1.7dBi
Bandwidth	1200-1300MHz	V.S.W.R	<1.5
Radiation pattern	Omni-directional	Cable	RG402-SMA